

# Rate Schedules 2026



Lincoln Electric System

Approved 1/1/2026

**SUMMARY OF RATE SCHEDULES REVISIONS  
FOR RATES EFFECTIVE  
JANUARY 1, 2026**

- Charges have been updated consistent with a proposed 3.0% system-wide rate increase
- Updated the LLP with Market Energy rate language to reflect billing at MW level
- Updated the LLP with Market Energy rate Applicability language to mention the possible execution of other agreements between LES and the customer
- Removed 345 kV eligibility from the LLP with Market Energy rate
- Added eligibility and rates to the Renewable Generation Standby Capacity Rider to include General Service Demand rate class
- Removed ramp limits from LLP, LLP-TOU, LLP-OPD, LLP-M, SFP, and LPC class terms and conditions
- The LPC and LPC-OPD rates will be closed to new customers effective January 1<sup>st</sup>, 2026 and will be discontinued no later than January 1<sup>st</sup>, 2027
- RNM and RG schedules Tier 2 definitions updated, extending total customer renewable generation and time limit of Tier 2 period

## INTRODUCTION

Retail Rates (including those items listed under Miscellaneous) are approved by the LES Administrative Board and the Lincoln City Council pursuant to Lincoln Municipal Code Chapter 4.24.

Non-Retail Pricing is approved by the LES Administrative Board.

Capitalized terms in the Rate Schedules are defined in the Service Regulations.

Rate Schedules (tariff) list the various types and amounts of charges that can be billed to customers in a particular rate category. These charges include the customer charge, the rate for energy, the demand charge, charges for low power factor, and other charges.

A Rider is an addition to the Rate Schedule and is typically voluntary. A Rider defines and offers provisions and requirements not included in the Rate Schedules.

**RATE SCHEDULES  
TABLE OF CONTENTS**

	<u>Rate Code</u>	<u>Page</u>
<b>Retail Pricing</b>		
Residential Service	01 & 03 <sup>(1)</sup>	1
General Service	10 & 13 <sup>(2)</sup>	3
Heating Service	21 & 23 <sup>(2)</sup>	5
General Service-Demand	11 & 12 <sup>(2)</sup>	7
Large Light and Power	15, 16 <sup>(2)</sup> & 39 <sup>(2)</sup>	10
Large Light and Power Time-Of-Use Demand	30, 31 <sup>(2)</sup> , 32 <sup>(2)</sup>	13
Large Light & Power - Off-Peak Daily	27, 28 <sup>(2)</sup> , 29 <sup>(2)</sup>	17
Supplemental Firm Power	61, 62	21
Transmission Facilities	33	25
Cogeneration - 35 kV	42	27
Large Power Customer	44, 45 <sup>(2)</sup> & 46 <sup>(2)</sup>	32
Large Power Customer - Off-Peak Daily	47, 48 <sup>(2)</sup> & 49 <sup>(2)</sup>	35
Large Power with Market Energy – 115 kV	55	39
Security Lighting	20	41
Traffic Lighting Service	24	43
Street Lighting Service	26	44
Curtailment Rider		46
Economic Development Rider		48
Interruptible Service Rider		50
Pole Attachment	50	52
Tax Clause		54
 <b>Non-Retail Pricing</b>		
Virtual Net Metering Rider		55
Renewable Net Metering Rider		58
Renewable Energy Certificate Rider		61
Renewable Generation		63
SunShares Rider		67
Cogeneration and Small Power Production		68
Renewable Generation Standby Capacity Rider		70
Multi-tenant Shared Solar		75
Shared Renewable Credit Allocation		78
Norris Public Power District	90	79
Service Fees		81
 <b>City Dividend for Utility Ownership</b>		
City Dividend for Utility Ownership		83

Notes:

<sup>(1)</sup> Rate Code 03 is Residential with Electric Heating.

<sup>(2)</sup> Rate Codes 12, 13, 16, 31, 28, 45, and 48 receive service at the primary voltage level. Rate Codes 32,39, 41, 42, 46 and 49 receive service at the 35 kV voltage level.

**Schedule RS - RESIDENTIAL SERVICE - 01 (Standard) & 03 (with Electric Heating)**

**AVAILABLE:** Within Lincoln, Nebraska, and the LES Service Area.

**APPLICABLE:** To single family residences and individually metered apartments.

**CHARACTER OF SERVICE:** Single-phase, or three-phase if available, 60 Hertz alternating current, supplied at LES' standard voltages through an LES-owned meter.

**BILL:** Customer Charge + Facilities Charge + Energy Charge + All Riders (if applicable) + Service Fees (if applicable) + City Dividend for Utility Ownership + Sales Tax (if applicable); based on the RATE in effect and LES' Service Regulations. Plus, for BILLING PERIODS less than 27 days, on the CUSTOMER'S first and final BILLS, a per day credit times the difference between 30 and the actual number of days in the BILLING PERIOD.

**BILLING PERIOD:** Bills are rendered on the basis of the scheduled meter reading dates or a date agreeable with LES for final readings. Under normal conditions, BILLING PERIODS typically range from 27 to 35 days.

**SEASONAL PROVISION:** Summer and winter periods are defined as:

- Summer – The four-month period from June 1 through September 30
- Winter – The eight-month period from October 1 through May 31

Energy Charges on the BILL will be prorated between seasons in transitional months (i.e., June and October) according to the number of days corresponding to each season covered by the BILL.

**RATE:**

<b>RESIDENTIAL</b>	<b>Summer</b>	<b>Winter</b>
Customer Charge \$/BILL	\$5.15	
Facilities Level 1 Charge \$/BILL	\$30.50	
Less than 27 day billing period credit Level 1 \$/day (first & final bills)	\$1.02	
Facilities Level 2 Charge \$/BILL	\$45.00	
Less than 27 day billing period credit Level 2 \$/day (first & final bills)	\$1.50	
Facilities Level 3 Charge \$/BILL	\$69.00	
Less than 27 day billing period credit Level 3 \$/day (first & final bills)	\$2.30	
Facilities Charge Three Phase \$/BILL	\$69.00	
Less than 27 day billing period credit Three Phase \$/day (first & final bills)	\$2.30	
Energy Charge \$/kWh	\$0.0782	\$0.0560

## **Schedule RS - RESIDENTIAL SERVICE - 01 (Standard) & 03 (with Electric Heating)**

**FACILITIES LEVEL:** Facilities Charges are based on average monthly energy for bills rendered during the twelve-month period of December 1 through November 30. LES will assign CUSTOMERS to the applicable Facilities Level. Newly constructed single family dwelling services, with no prior energy usage history, will initially be assigned to Level 2. Newly constructed multi-family dwelling services, with no prior energy usage history, will initially be assigned to Level 1. Levels are reviewed and changed as necessary each January 1. Exceptions to the below thresholds for Facilities Level assignments will only be made in rare instances and with the approval of LES.

Level 1 – Average monthly energy less than 800 kWh

Level 2 – Average monthly energy 800 kWh to 1,500 kWh

Level 3 – Average monthly energy greater than 1,500 kWh

**RESIDENTIAL ELECTRIC HEATING WITH SECOND METER:** Existing residential CUSTOMERS, where service has been provided for electric heating purposes only and is metered on a separate circuit, shall have energy use from these two services combined into one BILL. This type of electric heating service is only available to existing services and is not available for application to new service requests.

### **TERMS AND CONDITIONS:**

1. Service will be furnished subject to LES' policies and Service Regulations.
2. **TERMS OF PAYMENT - BILLS** on active accounts are due in full 23 days after rendered. **BILLS** on final accounts are due upon receipt or the date of the most recently issued **BILL**, whichever is later. Any past due amounts are subject to LES policies regarding termination of electric service and applicable Service Fees. Charges are subject to all applicable State and Local sales tax.
3. **FLUCTUATING LOADS AND HARMONICS** – CUSTOMERS operating equipment causing harmonic currents and/or highly fluctuating or large instantaneous demands, including, but not limited to, variable speed drives, motor starting, welders and X-ray machines, shall be required to pay all nonbetterment costs of corrective action required to maintain acceptable service quality to the CUSTOMER and not interfere with service on LES' lines or to other CUSTOMERS. See System Disturbances and Service Disruptions, and Disconnection of Electric Service in the Service Regulations.
4. **COGENERATION OR SMALL POWER PRODUCTION** - Refer to Customer-Owned Generation in the Service Regulations.

### **Schedule GS - GENERAL SERVICE - 10 (Secondary) & 13 (Primary)**

**AVAILABLE:** Within Lincoln, Nebraska, and the LES Service Area.

**APPLICABLE:** A CUSTOMER will receive service on this schedule if the following conditions are met:

- a. Energy usage does not exceed 25,000 kWh per BILLING PERIOD for each of nine consecutive BILLING PERIODS, and
- b. The CUSTOMER'S demand does not exceed 100 kW in two summer BILLING PERIODS including the current BILLING PERIOD and all BILLING PERIODS in the preceding 11 months.
- c. For new CUSTOMER accounts, usage and demand projections will be prepared by LES' Energy Delivery Division and the account will be placed on the appropriate schedule.
- d. OUTDOOR RECREATIONAL LIGHTING, as defined in the TERMS AND CONDITIONS, is not subject to the limitation of (b) above.

**CHARACTER OF SERVICE:** Single-phase, or three-phase if available, 60 Hertz alternating current, supplied at LES' standard voltages through an LES-owned meter.

**BILL:** Customer Charge + Facilities Charge + Energy Charge + All Riders (if applicable) + Service Fees (if applicable) + City Dividend for Utility Ownership + Sales Tax (if applicable); based on the RATE in effect and LES' Service Regulations. Plus, for BILLING PERIODS less than 27 days, on the CUSTOMER'S first and final BILLS, a per day credit times the difference between 30 and the actual number of days in the BILLING PERIOD.

**BILLING PERIOD:** Bills are rendered on the basis of the scheduled meter reading dates or a date agreeable with LES for final readings. Under normal conditions, BILLING PERIODS typically range from 27 to 35 days.

**SEASONAL PROVISION:** Summer and winter periods are defined as:

Summer – The four-month period from June 1 through September 30

Winter – The eight-month period from October 1 through May 31

Energy Charges on the BILL will be prorated between seasons in transitional months (i.e., June and October) according to the number of days corresponding to each season covered by the BILL.

**Schedule GS - GENERAL SERVICE - 10 (Secondary) & 13 (Primary)**

**RATE:**

<b>GENERAL SERVICE</b>	<b>Summer</b>	<b>Winter</b>
Customer Charge \$/BILL	\$6.50	
Facilities Charge \$/BILL	\$31.00	
Less than 27 day billing period credit \$/day (first & final bills)	\$1.03	
Facilities Charge Three Phase \$/BILL	\$95.50	
Less than 27 day billing period credit Three Phase \$/day (first & final bills)	\$3.18	
Facilities Charge Primary \$/BILL	\$50.00	
Less than 27 day billing period credit Primary \$/day (first & final bills)	\$1.67	
Energy Charge Secondary \$/kWh	\$0.1055	\$0.0655
Energy Charge Primary \$/kWh	\$0.0975	\$0.0620

**PRIMARY VOLTAGE DELIVERY:** Where the CUSTOMER takes service and is metered at an available LES standard primary distribution voltage of either 7,200/12,470 volts three phase, four wire or 34,500 volts three phase, three wire; and the CUSTOMER owns, operates and maintains all voltage transformation and other distribution equipment past the primary meter.

**TERMS AND CONDITIONS:**

1. Service will be furnished subject to LES' policies and Service Regulations.
2. TERMS OF PAYMENT - BILLS on active accounts are due in full 23 days after rendered. BILLS on final accounts are due upon receipt or the date of the most recently issued BILL, whichever is later. Any past due amounts are subject to LES policies regarding termination of electric service and applicable Service Fees. Charges are subject to all applicable State and Local sales tax.
3. FLUCTUATING LOADS AND HARMONICS – CUSTOMERs operating equipment causing harmonic currents and/or highly fluctuating or large instantaneous demands, including, but not limited to, variable speed drives, motor starting, welders and X-ray machines, shall be required to pay all nonbetterment costs of corrective action required to maintain acceptable service quality to the CUSTOMER and not interfere with service on LES' lines or to other CUSTOMERS. See System Disturbances and Service Disruptions, and Disconnection of Electric Service in the Service Regulations.
4. COGENERATION OR SMALL POWER PRODUCTION - Refer to Customer-Owned Generation in the Service Regulations.
5. OUTDOOR RECREATIONAL LIGHTING is metered service to off-peak, dusk-to-dawn area lighting for outdoor recreational facilities. OUTDOOR RECREATIONAL LIGHTING service must be wired and metered separate from any use other than OUTDOOR RECREATIONAL LIGHTING so that only OUTDOOR RECREATIONAL LIGHTING fixtures are on this metered circuit.

**Schedule HS - HEATING SERVICE - 21 (Secondary) & 23 (Primary)**

*The HS rate will be closed to new customers beginning January 1<sup>st</sup> 2025. The rate will be discontinued no later than December 31<sup>st</sup>, 2030.*

**AVAILABLE:** Within Lincoln, Nebraska, and the LES Service Area.

**APPLICABLE:** To any nonresidential CUSTOMER for space heating and/or approved water heating installations where this Heating Service is supplied through a separately metered circuit. For the Heating Service, summer demands shall not exceed the highest winter demand of the past 12 months. An exception to this demand requirement includes heat pump technologies including water loop and air-to-air systems.

A Heating Service CUSTOMER will receive the Large Heating Service classification if that CUSTOMER'S energy usage is greater than 25,000 kWh per BILLING PERIOD for two BILLING PERIODS, including the current BILLING PERIOD and all BILLING PERIODS in the preceding 11 months.

Removal from the Large Heating Service classification will occur when the CUSTOMER'S energy usage fails to exceed 25,000 kWh per BILLING PERIOD for 12 consecutive months.

**CHARACTER OF SERVICE:** Single-phase, or three-phase if available, 60 Hertz alternating current, supplied at LES' standard voltages through an LES-owned meter.

**BILL:** Customer Charge + Facilities Charge + Energy Charge + All Riders (if applicable) + Service Fees (if applicable) + City Dividend for Utility Ownership + Sales Tax (if applicable); based on the RATE in effect and LES' Service Regulations. Plus, for BILLING PERIODS less than 27 days, on the CUSTOMER'S first and final BILLS, a per day credit times the difference between 30 and the actual number of days in the BILLING PERIOD.

**BILLING PERIOD:** BILLS are rendered on the basis of the scheduled meter reading dates or a date agreeable with LES for final readings. Under normal conditions, BILLING PERIODS typically range from 27 to 35 days.

**SEASONAL PROVISION:** Summer and winter periods are defined as:

Summer – The four-month period from June 1 through September 30

Winter – The eight-month period from October 1 through May 31

Energy Charges on the BILL will be prorated between seasons in transitional months (i.e., June and October) according to the number of days corresponding to each season covered by the BILL.

**Schedule HS - HEATING SERVICE - 21 (Secondary) & 23 (Primary)**

*The HS rate will be closed to new customers beginning January 1<sup>st</sup> 2025. The rate will be discontinued no later than December 31<sup>st</sup>, 2030.*

**RATE:**

<b>HEATING SERVICE</b>	<b>Summer</b>	<b>Winter</b>
Customer Charge \$/BILL	\$5.30	
Facilities Charge \$/BILL	\$60.00	
Less than 27 day billing period credit \$/day (first & final bills)	\$2.00	
Facilities Charge Three Phase \$/BILL	\$230.00	
Less than 27 day billing period credit Three Phase \$/day (first & final bills)	\$7.67	
Facilities Charge Large \$/BILL	\$475.00	
Less than 27 day billing period credit Large \$/day (first & final bills)	\$15.83	
Facilities Charge Primary \$/BILL	\$375.00	
Less than 27 day billing period credit Primary \$/day (first & final bills)	\$12.50	
Energy Charge Secondary \$/kWh	\$0.1010	\$0.0730
Energy Charge Primary \$/kWh	\$0.0970	\$0.0710

**TERMS AND CONDITIONS:**

1. Service will be furnished subject to LES' policies and Service Regulations.
2. TERMS OF PAYMENT - BILLS on active accounts are due in full 23 days after rendered. BILLS on final accounts are due upon receipt or the date of the most recently issued BILL, whichever is later. Any past due amounts are subject to LES policies regarding termination of electric service and applicable Service Fees. Charges are subject to all applicable State and Local sales tax.
3. The installation of the main disconnect, meter socket and other equipment required to accept service under this schedule (except the Meter), shall be arranged and paid for by the CUSTOMER.
4. When the same permanently installed all-electric equipment is used for both heating and cooling, such as a heat pump (and certain other combination units upon specific approval) this rate schedule shall apply.
5. FLUCTUATING LOADS AND HARMONICS – CUSTOMERs operating equipment causing harmonic currents and/or highly fluctuating or large instantaneous demands, including, but not limited to, variable speed drives, motor starting, welders and X-ray machines, shall be required to pay all nonbetterment costs of corrective action required to maintain acceptable service quality to the CUSTOMER and not interfere with service on LES' lines or to other CUSTOMERs. See System Disturbances and Service Disruptions, and Disconnection of Electric Service in the Service Regulations.
6. COGENERATION OR SMALL POWER PRODUCTION – Refer to Customer-Owned Generation in the Service Regulations.

## **Schedule GSD - GENERAL SERVICE-DEMAND - 11 (Secondary) & 12 (Primary)**

**AVAILABLE:** Within Lincoln, Nebraska, and the LES Service Area.

**APPLICABLE:** A CUSTOMER will receive service on this schedule if the LLP schedule is not applicable and if any of the following conditions are met:

- (a) Energy usage is greater than 25,000 kWh per BILLING PERIOD for each of nine consecutive BILLING PERIODS.
- (b) The CUSTOMER'S demand is greater than 100 kW in two summer BILLING PERIODS including the current summer BILLING PERIOD and all summer BILLING PERIODS in the preceding 11 months.
- (c) For new CUSTOMER accounts, usage and demand projections will be prepared by LES' Energy Delivery Division and the account will be placed on the appropriate schedule.

The minimum BILLING DEMAND for this schedule is 25 kW.

Removal from the GSD to the GS schedule will take place if the account demonstrates in the previous 12 BILLING PERIODS no summer BILLING DEMAND greater than 100 kW and no energy usage greater than 25,000 kWh per BILLING PERIOD for nine consecutive BILLING PERIODS.

Accounts are required to stay on a rate schedule for a minimum of 12 months.

**CHARACTER OF SERVICE:** Single-phase, or three-phase if available, 60 Hertz alternating current, supplied at LES' standard voltages through an LES-owned meter.

**BILL:** Customer Charge + Demand Charge + Facilities Charge + Energy Charge + Dual Primary Service Charge (if applicable) + All Riders (if applicable) + Service Fees (if applicable) + City Dividend for Utility Ownership + Sales Tax (if applicable); based on the RATE in effect and LES' Service Regulations.

**BILLING PERIOD:** BILLS are rendered on a calendar-month basis or a date agreeable with LES for final readings.

**SEASONAL PROVISION:** Summer and winter periods are defined as:

- Summer – The four-month period from June 1 through September 30
- Winter – The eight-month period from October 1 through May 31

**Schedule GSD - GENERAL SERVICE-DEMAND - 11 (Secondary) & 12 (Primary)**

**RATE:**

<b>GENERAL SERVICE DEMAND</b>	<b>Summer</b>	<b>Winter</b>
Customer Charge \$/BILL	\$25.00	
Demand Charge Secondary \$/kW of BILLING DEMAND	\$14.50	
Facilities Charge Secondary \$/kW of BILLING DEMAND	\$7.25	
Demand Charge Primary \$/kW of BILLING DEMAND	\$14.25	
Facilities Charge Primary \$/kW of BILLING DEMAND	\$5.25	
Energy Charge Secondary \$/kWh	\$0.0277	\$0.0250
Energy Charge Primary \$/kWh	\$0.0270	\$0.0245
Dual Primary Service Charge \$/kW of DUAL PRIMARY DEMAND	\$5.25	

**MAXIMUM DEMAND:** The highest integrated kilowatt load during any 30-minute period occurring in the BILLING PERIOD for which the determination is made.

**BILLING DEMAND:** Either (a), (b) or (c), whichever is higher:

- (a) The MAXIMUM DEMAND occurring during the BILLING PERIOD.
- (b) 65 percent of the highest MAXIMUM DEMAND established for the BILLS rendered for June, July, August or September of the preceding 11 months.
- (c) 25 kW.

**PRIMARY VOLTAGE DELIVERY:** Where the CUSTOMER takes service and is metered at an available LES standard primary distribution voltage of either 7,200/12,470 volts three phase, four wire or 34,500 volts three phase, three wire; and the CUSTOMER owns, operates and maintains all voltage transformation and other distribution equipment past the primary meter.

**DUAL PRIMARY SERVICE:** When LES provides capacity from two primary service sources and where the CUSTOMER controls the switchgear transferring load between the two primary service sources. One of the services may be sufficient to serve part of the CUSTOMER'S load, but not all of the load. The CUSTOMER-controlled switchgear shall have either a break before make transfer switch or two keyed interlock single throw switches within the same lineup to prevent paralleling of the two primary service sources. LES may also require Aid-to-Construction payments for the dual service installation.

**Schedule GSD - GENERAL SERVICE-DEMAND - 11 (Secondary) & 12 (Primary)**

**DUAL PRIMARY DEMAND:** Either (a) or (b), whichever is applicable:

- (a) Full service: When both primary services are adequate for the CUSTOMER'S entire load, DUAL PRIMARY DEMAND will be the BILLING DEMAND.
- (b) Partial service: When one of the primary services is only adequate for part of the CUSTOMER'S load, DUAL PRIMARY DEMAND will be either (1), (2) or (3), whichever is higher:
  - (1) The CUSTOMER requested kilowatt capacity of the DUAL PRIMARY SERVICE providing partial service.
  - (2) The MAXIMUM DEMAND during the BILLING PERIOD of the DUAL PRIMARY SERVICE providing partial service.
  - (3) 100 percent of the highest MAXIMUM DEMAND of the preceding 11 months of the DUAL PRIMARY SERVICE providing partial service.

**TERMS AND CONDITIONS:**

- 1. Service will be furnished subject to LES' policies and Service Regulations.
- 2. TERMS OF PAYMENT - BILLS on active accounts are due in full 23 days after rendered. BILLS on final accounts are due upon receipt or the date of the most recently issued BILL, whichever is later. Any past due amounts are subject to LES policies regarding termination of electric service and applicable Service Fees. Charges are subject to all applicable State and Local sales tax.
- 3. FLUCTUATING LOADS AND HARMONICS – CUSTOMERs operating equipment causing harmonic currents and/or highly fluctuating or large instantaneous demands, including, but not limited to, variable speed drives, motor starting, welders and X-ray machines, shall be required to pay all nonbetterment costs of corrective action required to maintain acceptable service quality to the CUSTOMER and not interfere with service on LES' lines or to other CUSTOMERS. See System Disturbances and Service Disruptions, and Disconnection of Electric Service in the Service Regulations.
- 4. COGENERATION OR SMALL POWER PRODUCTION - Refer to Customer-Owned Generation in the Service Regulations.

**Schedule LLP - LARGE LIGHT AND POWER  
15 (Secondary), 16 (Primary), & 39 (35 kV)**

**AVAILABLE:** Within Lincoln, Nebraska, and the LES Service Area.

**APPLICABLE:** A CUSTOMER will receive service on this schedule if any of the following conditions are met:

- (a) Energy usage is greater than 100,000 kWh per BILLING PERIOD for each of nine consecutive BILLING PERIODS.
- (b) The CUSTOMER'S demand is greater than 400 kW but less than 20,000 kW in any two summer BILLING PERIODS including the current summer BILLING PERIOD and all summer BILLING PERIODS in the preceding 11 months.
- (c) For new CUSTOMER accounts added to LES, usage and demand projections will be prepared by LES' Energy Delivery Division and the account will be placed on the appropriate schedule.

CUSTOMERS will be moved from the LLP to LPC schedule if they display demand greater than or equal to 4,000 kW per BILLING PERIOD for nine consecutive BILLING PERIODS.

Removal from the LLP to the GSD schedule will take place if the account demonstrates in the previous 12 BILLING PERIODS no summer BILLING DEMAND greater than 400 kW and no energy usage greater than 100,000 kWh per BILLING PERIOD for nine consecutive BILLING PERIODS.

Removal from the LLP to the GS schedule will take place if the account demonstrates in the previous 12 BILLING PERIODS no summer BILLING DEMAND greater than 100 kW and no energy usage greater than 25,000 kWh per BILLING PERIOD for nine consecutive BILLING PERIODS.

Accounts are required to stay on a rate schedule for a minimum of 12 months.

**CHARACTER OF SERVICE:** Three-phase, 60 Hertz alternating current, supplied at LES' standard voltages through an LES-owned meter.

**BILL:** Customer Charge + Demand Charge + Facilities Charge + Energy Charge + Dual Primary Service Charge (if applicable) + Excess kVAR Charge (if applicable) + All Riders (if applicable) + Service Fees (if applicable) + City Dividend for Utility Ownership + Sales Tax (if applicable); based on the RATE in effect and LES' Service Regulations.

**BILLING PERIOD:** BILLS are rendered on a calendar-month basis or a date agreeable with LES for final readings.

**SEASONAL PROVISION:** Summer and winter periods are defined as:

- Summer – The four-month period from June 1 through September 30
- Winter – The eight-month period from October 1 through May 31

**Schedule LLP - LARGE LIGHT AND POWER  
 15 (Secondary), 16 (Primary), & 39 (35 kV)**

**RATE:**

<b>LARGE LIGHT AND POWER</b>		<b>Summer</b>	<b>Winter</b>
Customer Charge \$/BILL		\$450.00	
Demand Charge Secondary \$/kW of BILLING DEMAND		\$17.75	
Facilities Charge Secondary \$/kW of BILLING DEMAND		\$7.42	
Demand Charge Primary \$/kW of BILLING DEMAND		\$17.25	
Facilities Charge Primary \$/kW of BILLING DEMAND		\$5.90	
Demand Charge 35 kV \$/kW of BILLING DEMAND		\$17.25	
Facilities Charge 35 kV \$/kW of BILLING DEMAND		\$2.40	
Energy Charge Secondary \$/kWh		\$0.0255	\$0.0245
Energy Charge Primary and 35 kV \$/kWh		\$0.0242	\$0.0235
Excess kVAR Charge \$/kVAR for all EXCESS kVARs		\$2.60	
Dual Primary Service Charge \$/kW of DUAL PRIMARY DEMAND		\$3.50	

**MAXIMUM DEMAND:** The highest integrated kilowatt load during any 30-minute period occurring in the BILLING PERIOD for which the determination is made.

**BILLING DEMAND:** Either (a) or (b), whichever is higher:

- (a) The MAXIMUM DEMAND occurring during the BILLING PERIOD.
- (b) 65 percent of the highest MAXIMUM DEMAND established for the BILLS rendered for June, July, August or September of the preceding 11 months.

**PRIMARY VOLTAGE DELIVERY:** Where the CUSTOMER takes service and is metered at an available LES standard primary distribution voltage of either 7,200/12,470 volts three phase, four wire or 34,500 volts three phase, three wire; and the CUSTOMER owns, operates and maintains all voltage transformation and other distribution equipment past the primary meter.

**DUAL PRIMARY SERVICE:** When LES provides capacity from two primary service sources and where the CUSTOMER controls the switchgear transferring load between the two primary service sources. One of the services may be sufficient to serve part of the CUSTOMER'S load, but not all of the load. The CUSTOMER controlled switchgear shall have either a break before make transfer switch or two keyed interlock single throw switches within the same lineup to prevent paralleling of the two primary service sources. LES may also require Aid-to-Construction payments for the dual service installation.

**DUAL PRIMARY DEMAND:** Either (a) or (b), whichever is applicable:

- (a) Full service: When both primary services are adequate for the CUSTOMER'S entire load, DUAL PRIMARY DEMAND will be the BILLING DEMAND.
- (b) Partial service: When one of the primary services is only adequate for part of the CUSTOMER'S load, DUAL PRIMARY DEMAND will be either (1), (2) or (3), whichever is higher:

**Schedule LLP - LARGE LIGHT AND POWER  
15 (Secondary), 16 (Primary), & 39 (35 kV)**

- (1) The CUSTOMER requested kilowatt capacity of the DUAL PRIMARY SERVICE providing partial service.
- (2) The MAXIMUM DEMAND during the BILLING PERIOD of the DUAL PRIMARY SERVICE providing partial service.
- (3) 100 percent of the highest MAXIMUM DEMAND of the preceding 11 months of the DUAL PRIMARY SERVICE providing partial service.

**EXCESS KVARs:** Maximum kVARs for the BILLING PERIOD minus the product of the MAXIMUM DEMAND for the BILLING PERIOD multiplied by .39523 (representing a power factor of 93 percent). The CUSTOMER will be responsible for limiting kVAR requirements at or below this calculated level at all times and will be charged for EXCESS KVARs.

**TERMS AND CONDITIONS:**

1. Service will be furnished subject to LES' policies and Service Regulations.
2. TERMS OF PAYMENT - BILLS on active accounts are due in full 23 days after rendered. LES may, in its discretion, require prepayment for services, render bills on a more frequent basis and require payment on a more frequent basis. Additionally, LES may require payments to be made using electronic means (wire, ACH). BILLS on final accounts are due upon receipt or the date of the most recently issued BILL, whichever is later. Any past due amounts are subject to LES policies regarding termination of electric service and applicable Service Fees. Charges are subject to all applicable State and Local sales tax.
3. FLUCTUATING LOADS AND HARMONICS – CUSTOMERs operating equipment causing harmonic currents and/or highly fluctuating or large instantaneous demands, including, but not limited to, variable speed drives, motor starting, welders and X-ray machines, shall be required to pay all nonbetterment costs of corrective action required to maintain acceptable service quality to the CUSTOMER and not interfere with service on LES' lines or to other CUSTOMERs. See System Disturbances and Service Disruptions, and Disconnection of Electric Service in the Service Regulations.
4. COGENERATION OR SMALL POWER PRODUCTION - Refer to Customer-Owned Generation in the Service Regulations.

**Schedule LLP-TOUD - LARGE LIGHT AND POWER TIME-OF-USE DEMAND  
30 (Secondary), 31 (Primary), & 32 (35 kV)**

**AVAILABLE:** Within Lincoln, Nebraska, and the LES Service Area.

**APPLICABLE:** A CUSTOMER may receive service on this schedule if any of the following conditions are met:

- (a) Energy usage is greater than 100,000 kWh per BILLING PERIOD for each of nine consecutive BILLING PERIODS.
- (b) The CUSTOMER'S demand is greater than 400 kW but less than 20,000 kW in any two summer BILLING PERIODS including the current summer BILLING PERIOD and all summer BILLING PERIODS in the preceding 11 months.
- (c) For new CUSTOMER accounts, the CUSTOMER will not be placed on this rate schedule until a complete year of billing history has been established. This requirement may be waived at LES' option, if the CUSTOMER agrees to an estimate of the ON-PEAK AND OFF-PEAK BILLING DEMAND made by LES which may be used for billing purposes.

Removal from this schedule to another applicable LLP schedule may take place after a minimum of one year on this schedule.

Removal from this LLP to GSD schedule will take place if the account demonstrates in the previous 12 BILLING PERIODS no summer BILLING DEMAND greater than 400 kW and no energy usage greater than 100,000 kWh per BILLING PERIOD for nine consecutive BILLING PERIODS.

Removal from the LLP to the GS schedule will take place if the account demonstrates in the previous 12 BILLING PERIODS no summer BILLING DEMAND greater than 100 kW and no energy usage greater than 25,000 kWh per BILLING PERIOD for nine consecutive BILLING PERIODS.

**CHARACTER OF SERVICE:** Three-phase, 60 Hertz alternating current, supplied at LES' standard voltages through an LES-owned meter.

**BILL:** Customer Charge + Off Peak Demand Charge + On Peak Demand Charge + Facilities Charge + Energy Charge + Dual Primary Service Charge (if applicable) + Excess kVAR Charge (if applicable) + All Riders (if applicable) + Service Fees (if applicable) + City Dividend for Utility Ownership + Sales Tax (if applicable); based on the RATE in effect and LES' Service Regulations.

**BILLING PERIOD:** BILLS are rendered on a calendar-month basis or a date agreeable with LES for final readings.

**ENERGY SEASONAL PROVISION:** Summer and winter periods are defined as:

- Summer – The four-month period from June 1 through September 30
- Winter – The eight-month period from October 1 through May 31

**DEMAND SEASONAL PROVISION:** Summer, winter, and shoulder periods are defined as:

- Summer – The four-month period from June 1 through September 30
- Shoulder – The two-month period of May 1 to May 31 and October 1 through October 31
- Winter – The six-month period from November 1 through April 30

**Schedule LLP-TOUD - LARGE LIGHT AND POWER TIME-OF-USE DEMAND  
 30 (Secondary), 31 (Primary), & 32 (35 kV)**

**RATE:**

<b>LARGE LIGHT AND POWER TIME-OF-USE DEMAND</b>	<b>Summer</b>	<b>Winter</b>
Customer Charge \$/BILL	\$450.00	
Demand Charge Secondary \$/kW of ON-PEAK BILLING DEMAND	\$13.00	
Demand Charge Secondary \$/kW of OFF-PEAK BILLING DEMAND	\$4.50	
Facilities Charge Secondary \$/kW of PEAK BILLING DEMAND	\$5.50	
Demand Charge Primary \$/kW of ON-PEAK BILLING DEMAND	\$12.50	
Demand Charge Primary \$/kW of OFF-PEAK BILLING DEMAND	\$4.00	
Facilities Charge Primary \$/kW of PEAK BILLING DEMAND	\$5.00	
Demand Charge 35 kV \$/kW of ON-PEAK BILLING DEMAND	\$12.50	
Demand Charge 35 kV \$/kW of OFF-PEAK BILLING DEMAND	\$4.00	
Facilities Charge 35 kV \$/kW of PEAK BILLING DEMAND	\$2.40	
Energy Charge Secondary \$/kWh	\$0.0265	\$0.0243
Energy Charge Primary and 35 kV \$/kWh	\$0.0252	\$0.0232
Excess kVAR Charge \$/kVAR for all EXCESS kVARs	\$2.60	
Dual Primary Service Charge \$/kW of DUAL PRIMARY DEMAND	\$2.40	

**WINTER OFF-PEAK PERIOD:** The WINTER OFF-PEAK PERIOD is every day (Monday through Sunday) 12 a.m. - 7 a.m., 12 p.m. - 6 p.m., and 9 p.m. -12 a.m. in the BILLING PERIODS of January, February, March, April, November, and December as recorded by LES' billing meters.

**WINTER ON-PEAK PERIOD:** The WINTER ON-PEAK PERIOD is every day (Monday through Sunday) 7 a.m. - 12 p.m. and 6 p.m. - 9 p.m. in the BILLING PERIODS of January, February, March, April, November, and December as recorded by LES' billing meters.

**SHOULDER OFF-PEAK PERIOD:** The SHOULDER OFF-PEAK PERIOD is every day (Monday through Sunday) 12 a.m.- 12 p.m. and 9 p.m. - 12 a.m. in the BILLING PERIODS of May and October as recorded by LES' billing meters.

**SHOULDER ON-PEAK PERIOD:** The SHOULDER ON-PEAK PERIOD is every day (Monday through Sunday) 12 p.m. - 9 p.m. in the BILLING PERIODS of May and October as recorded by LES' billing meters.

**SUMMER OFF-PEAK PERIOD:** The SUMMER OFF-PEAK PERIOD is every day (Monday through Sunday) 12 a.m. - 12 p.m. and 9 p.m. - 12 a.m. in the BILLING PERIODS of June, July, August, and September as recorded by LES' billing meters.

**SUMMER ON-PEAK PERIOD:** The SUMMER ON-PEAK PERIOD is every day (Monday through Sunday) 12 p.m. - 9 p.m. in the BILLING PERIODS of June, July, August, and September as recorded by LES' billing meters.

**Schedule LLP-TOUD - LARGE LIGHT AND POWER TIME-OF-USE DEMAND  
30 (Secondary), 31 (Primary), & 32 (35 kV)**

**ON-PEAK DEMAND:** The highest integrated kilowatt load during any 30-minute period occurring in the ON-PEAK PERIOD during the BILLING PERIOD for which the determination is made.

**OFF-PEAK DEMAND:** The highest integrated kilowatt load during any 30-minute period occurring in the OFF-PEAK PERIOD during the BILLING PERIOD for which the determination is made.

**MAXIMUM DEMAND:** The highest integrated kilowatt load during any 30-minute period occurring in the BILLING PERIOD for which the determination is made.

**ON-PEAK DEMAND:** Either (a) or (b), whichever is higher:

- (a) The ON-PEAK DEMAND occurring during the ON-PEAK PERIOD during the BILLING PERIOD.
- (b) 65 percent of the highest MAXIMUM DEMAND established for the BILLS rendered for the preceding 11 months.

**OFF-PEAK DEMAND:** Either (a) or (b), whichever is higher:

- (a) The OFF-PEAK DEMAND occurring during the OFF-PEAK PERIOD during the BILLING PERIOD.
- (b) 65 percent of the highest MAXIMUM DEMAND established for the BILLS rendered for the preceding 11 months.

**PEAK BILLING DEMAND:** Either (a) or (b), whichever is higher:

- (a) The PEAK DEMAND occurring during the BILLING PERIOD.
- (b) 65 percent of the highest MAXIMUM DEMAND established for the BILLS rendered for June, July, August or September of the preceding 11 months.

**PRIMARY VOLTAGE DELIVERY:** Where the CUSTOMER takes service and is metered at an available LES standard primary distribution voltage of either 7,200/12,470 volts three phase, four wire or 34,500 volts three phase, three wire; and the CUSTOMER owns, operates and maintains all voltage transformation and other distribution equipment past the primary meter.

**DUAL PRIMARY SERVICE:** When LES provides capacity from two primary service sources and where the CUSTOMER controls the switchgear transferring load between the two primary service sources. One of the services may be sufficient to serve part of the CUSTOMER'S load, but not all of the load. The CUSTOMER controlled switchgear shall have either a break before make transfer switch or two keyed interlock single throw switches within the same lineup to prevent paralleling of the two primary service sources. LES may also require Aid-to-Construction payments for the dual service installation.

**Schedule LLP-TOUD - LARGE LIGHT AND POWER TIME-OF-USE DEMAND  
30 (Secondary), 31 (Primary), & 32 (35 kV)**

**DUAL PRIMARY DEMAND:** Either (a) or (b), whichever is applicable:

- (a) Full service: When both primary services are adequate for the CUSTOMER'S entire load, DUAL PRIMARY DEMAND will be the BILLING DEMAND.
- (b) Partial service: When one of the primary services is only adequate for part of the CUSTOMER'S load, DUAL PRIMARY DEMAND will be either (1), (2) or (3), whichever is higher:
  - (1) The CUSTOMER requested kilowatt capacity of the DUAL PRIMARY SERVICE providing partial service.
  - (2) The MAXIMUM DEMAND during the BILLING PERIOD of the DUAL PRIMARY SERVICE providing partial service.
  - (3) 100 percent of the highest MAXIMUM DEMAND of the preceding 11 months of the DUAL PRIMARY SERVICE providing partial service.

**EXCESS kVARS:** Maximum kVARS for the BILLING PERIOD minus the product of the MAXIMUM DEMAND for the BILLING PERIOD multiplied by .39523 (representing a power factor of 93 percent). The CUSTOMER will be responsible for limiting kVAR requirements at or below this calculated level at all times and will be charged for EXCESS kVARS.

**TERMS AND CONDITIONS:**

1. Service will be furnished subject to LES' policies and Service Regulations.
2. TERMS OF PAYMENT - BILLS on active accounts are due in full 23 days after rendered. LES may, in its discretion, require prepayment for services, render bills on a more frequent basis and require payment on a more frequent basis. Additionally, LES may require payments to be made using electronic means (wire, ACH). BILLS on final accounts are due upon receipt or the date of the most recently issued BILL, whichever is later. Any past due amounts are subject to LES policies regarding termination of electric service and applicable Service Fees. Charges are subject to all applicable State and Local sales tax.
3. FLUCTUATING LOADS AND HARMONICS – CUSTOMERs operating equipment causing harmonic currents and/or highly fluctuating or large instantaneous demands, including, but not limited to, variable speed drives, motor starting, welders and X-ray machines, shall be required to pay all nonbetterment costs of corrective action required to maintain acceptable service quality to the CUSTOMER and not interfere with service on LES' lines or to other CUSTOMERS. See System Disturbances and Service Disruptions, and Disconnection of Electric Service in the Service Regulations.
4. COGENERATION OR SMALL POWER PRODUCTION - Refer to Customer-Owned Generation in the Service Regulations.
5. PEAK PERIODS - CUSTOMERS will be given a 2-year notice prior to any changes to On-peak and Off-peak time periods.

**Schedule LLP-OPD – LARGE LIGHT AND POWER – OFF-PEAK DAILY  
27 (Secondary), 28 (Primary), & 29 (35 kV)**

**AVAILABLE:** Within Lincoln, Nebraska, and the LES Service Area.

**APPLICABLE:** CUSTOMERS may receive service on this schedule if any of the following conditions are met:

- (a) Energy usage is greater than 100,000 kWh per BILLING PERIOD for each of nine consecutive BILLING PERIODS.
- (b) The CUSTOMER'S demand is greater than 400 kW but less than 20,000 kW in two summer BILLING PERIODS including the current summer BILLING PERIOD and all summer BILLING PERIODS in the preceding 11 months.
- (c) For new CUSTOMER accounts, the CUSTOMER will not be placed on this rate schedule until a complete summer of billing history has been established. This requirement may be waived at LES' option, if the CUSTOMER agrees to an estimate of the SUMMER BASE BILLING DEMAND made by LES which may be used for billing purposes.

Removal from this schedule to another applicable LLP schedule may take place after a minimum of one year on this schedule.

Removal from this LLP to the GSD schedule will take place if the account demonstrates in the previous 12 BILLING PERIODS no summer BILLING DEMAND greater than 400 kW and no energy usage greater than 100,000 kWh per BILLING PERIOD for nine consecutive BILLING PERIODS.

Removal from the LLP to the GS schedule will take place if the account demonstrates in the previous 12 BILLING PERIODS no summer BILLING DEMAND greater than 100 kW and no energy usage greater than 25,000 kWh per BILLING PERIOD for nine consecutive BILLING PERIODS.

**CHARACTER OF SERVICE:** Three-phase, 60 Hertz alternating current, supplied at LES' standard voltages through an LES-owned meter.

**BILL:** Customer Charge + Demand Charge + Facilities Charge + Energy Charge + Dual Primary Service Charge (if applicable) + Excess kVAR Charge (if applicable) + All Riders (if applicable) + Service Fees (if applicable) + City Dividend for Utility Ownership + Sales Tax (if applicable); based on the RATE in effect and LES' Service Regulations.

**BILLING PERIOD:** BILLS are rendered on a calendar-month basis or a date agreeable with LES for final readings.

**SEASONAL PROVISION:** Summer and winter periods are defined as:

- Summer – The four-month period from June 1 through September 30
- Winter – The eight-month period from October 1 through May 31

**Schedule LLP-OPD – LARGE LIGHT AND POWER – OFF-PEAK DAILY  
 27 (Secondary), 28 (Primary), & 29 (35 kV)**

**RATE:**

<b>LARGE LIGHT AND POWER OFF-PEAK DAILY</b>	<b>Summer</b>	<b>Winter</b>
Customer Charge \$/BILL	\$450.00	
Demand Charge Secondary \$/kW of SUMMER BASE BILLING DEMAND	\$17.75	
PLUS Demand Charge Secondary \$/kW of OFF-PEAK EXCESS BILLING DEMAND	\$7.30	
Facilities Charge Secondary \$/kW of SUMMER BASE BILLING DEMAND	\$7.42	
PLUS Facilities Charge Secondary \$/kW of OFF-PEAK EXCESS BILLING DEMAND	\$7.42	
Demand Charge Primary \$/kW of SUMMER BASE BILLING DEMAND	\$17.25	
PLUS Demand Charge Primary \$/kW of OFF-PEAK EXCESS BILLING DEMAND	\$7.00	
Facilities Charge Primary \$/kW of SUMMER BASE BILLING DEMAND	\$5.90	
PLUS Facilities Charge Primary \$/kW of OFF-PEAK EXCESS BILLING DEMAND	\$5.90	
Demand Charge 35 kV \$/kW of SUMMER BASE BILLING DEMAND	\$17.25	
PLUS Demand Charge 35 kV \$/kW of OFF-PEAK EXCESS BILLING DEMAND	\$6.40	
Facilities Charge 35 kV \$/kW of SUMMER BASE BILLING DEMAND	\$2.40	
PLUS Facilities Charge 35 kV \$/kW of OFF-PEAK EXCESS BILLING DEMAND	\$2.40	
Energy Charge Secondary \$/kWh	\$0.0255	\$0.0245
Energy Charge Primary and 35 kV \$/kWh	\$0.0242	\$0.0235
Excess kVAR Charge \$/kVAR for all EXCESS kVARs	\$2.60	
Dual Primary Service Charge \$/kW of DUAL PRIMARY DEMAND	\$5.30	

**MAXIMUM DEMAND:** The highest integrated kilowatt load during any 30-minute period occurring in the BILLING PERIOD for which the determination is made.

**SUMMER ON-PEAK PERIOD:** The SUMMER ON-PEAK PERIOD is every weekday (Monday through Friday) between 2 p.m. and 8 p.m. (daylight saving time) in the summer BILLING PERIODS as recorded by LES' billing meters. Weekend days (Saturday and Sunday) and weekday observations (Federal Holiday designation) of Independence Day and Labor Day are not in the SUMMER ON-PEAK PERIOD.

**Schedule LLP-OPD – LARGE LIGHT AND POWER – OFF-PEAK DAILY  
27 (Secondary), 28 (Primary), & 29 (35 kV)**

**SUMMER BASE BILLING DEMAND:** Shall be (a) below unless the current billing is for a summer month; then the SUMMER BASE BILLING DEMAND shall be the greater of (a) or (b) below:

- (a) 100 percent of the MAXIMUM DEMAND occurring during the SUMMER ON-PEAK PERIOD established for the BILLS rendered for June, July, August or September of the preceding 11 months.
- (b) The MAXIMUM DEMAND occurring during the SUMMER ON-PEAK PERIOD of the current summer BILLING PERIOD.

**OFF-PEAK EXCESS BILLING DEMAND:** Shall be the current month's MAXIMUM DEMAND minus the SUMMER BASE BILLING DEMAND. Should the SUMMER BASE BILLING DEMAND be greater than the current BILLING PERIOD'S MAXIMUM DEMAND, the OFF-PEAK EXCESS BILLING DEMAND will be zero.

**BILLING DEMAND:** Either (a) or (b), whichever is higher:

- (a) The MAXIMUM DEMAND occurring during the BILLING PERIOD.
- (b) SUMMER BASE BILLING DEMAND.

**PRIMARY VOLTAGE DELIVERY:** Where the CUSTOMER takes service and is metered at an available LES standard primary distribution voltage of either 7,200/12,470 volts three phase, four wire or 34,500 volts three phase, three wire; and the CUSTOMER owns, operates and maintains all voltage transformation and other distribution equipment past the primary meter.

**DUAL PRIMARY SERVICE:** When LES provides capacity from two primary service sources and where the CUSTOMER controls the switchgear transferring load between the two primary service sources. One of the services may be sufficient to serve part of the CUSTOMER'S load, but not all of the load. The CUSTOMER controlled switchgear shall have either a break before make transfer switch or two keyed interlock single throw switches within the same lineup to prevent paralleling of the two primary service sources. LES may also require Aid-to-Construction payments for the dual service installation.

**DUAL PRIMARY DEMAND:** Either (a) or (b), whichever is applicable:

- (a) Full service: When both primary services are adequate for the CUSTOMER'S entire load, DUAL PRIMARY DEMAND will be the BILLING DEMAND.
- (b) Partial service: When one of the primary services is only adequate for part of the CUSTOMER'S load, DUAL PRIMARY DEMAND will be either (1), (2) or (3), whichever is higher:

**Schedule LLP-OPD – LARGE LIGHT AND POWER – OFF-PEAK DAILY  
27 (Secondary), 28 (Primary), & 29 (35 kV)**

- (1) The CUSTOMER requested kilowatt capacity of the DUAL PRIMARY SERVICE providing partial service.
- (2) The MAXIMUM DEMAND during the BILLING PERIOD of the DUAL PRIMARY SERVICE providing partial service.
- (3) 100 percent of the highest MAXIMUM DEMAND of the preceding 11 months of the DUAL PRIMARY SERVICE providing partial service.

**EXCESS kVARS:** Maximum kVARS for the BILLING PERIOD minus the product of the MAXIMUM DEMAND for the BILLING PERIOD multiplied by .39523 (representing a power factor of 93 percent). The CUSTOMER will be responsible for limiting kVAR requirements at or below this calculated level at all times and will be charged for EXCESS kVARS.

**TERMS AND CONDITIONS:**

1. Service will be furnished subject to LES' policies and Service Regulations.
2. TERMS OF PAYMENT - BILLS on active accounts are due in full 23 days after rendered. LES may, in its discretion, require prepayment for services, render bills on a more frequent basis and require payment on a more frequent basis. Additionally, LES may require payments to be made using electronic means (wire, ACH). BILLS on final accounts are due upon receipt or the date of the most recently issued BILL, whichever is later. Any past due amounts are subject to LES policies regarding termination of electric service and applicable Service Fees. Charges are subject to all applicable State and Local sales tax.
3. FLUCTUATING LOADS AND HARMONICS – CUSTOMERs operating equipment causing harmonic currents and/or highly fluctuating or large instantaneous demands, including, but not limited to, variable speed drives, motor starting, welders and X-ray machines, shall be required to pay all nonbetterment costs of corrective action required to maintain acceptable service quality to the CUSTOMER and not interfere with service on LES' lines or to other CUSTOMERS. See System Disturbances and Service Disruptions, and Disconnection of Electric Service in the Service Regulations.
4. COGENERATION OR SMALL POWER PRODUCTION - Refer to Customer-Owned Generation in the Service Regulations.

## **Schedule SF - SUPPLEMENTAL FIRM POWER 61 (Secondary) & 62 (Primary)**

**AVAILABLE:** Within Lincoln, Nebraska and the LES Service Area.

**APPLICABLE:** To Western Area Power Administration (WAPA) Preference Customers.

**TERM:** This schedule shall be effective August 1, 2018 and shall remain in effect until such time that it is superseded. The CUSTOMER shall remain on this rate schedule for a minimum of one year. The cost to provide service under this schedule can be reviewed by LES and is subject to change.

**CHARACTER OF SERVICE:** For supplemental power and energy deliveries through a LES-owned meter at 60 Hertz to the CUSTOMER within LES' available capacity. Supplemental power and energy shall be the power and energy required by the CUSTOMER over and above power and energy provided by WAPA, and if applicable the CUSTOMER'S generation, at the designated Point(s) of Delivery. Delivery shall be at primary or secondary voltage.

**BILL:** Customer Charge + Meter Charge + Demand Charge + Facilities Charge + Energy Charge + WAPA Distribution Energy Losses + Dual Primary Service Charge (if applicable) + Excess kVAR Charge (if applicable) + All Riders (if applicable) + Service Fees (if applicable) + City Dividend for Utility Ownership + Sales Tax (if applicable); based on the RATE in effect, LES' Service Regulations, and all contractual agreements.

**BILLING PERIOD:** BILLS are rendered on a calendar-month basis or a date agreeable with LES for final readings.

**SEASONAL PROVISION:** Summer and winter periods are defined as:

Summer – The four-month period from June 1 through September 30

Winter – The eight-month period from October 1 through May 31

Energy Charges on the BILL will be prorated between seasons in transitional months (i.e., June and October) according to the number of days corresponding to each season covered by the BILL.

**SUPPLEMENTAL FIRM POWER – 61 (Secondary) & 62 (Primary)**

**RATE:**

<b>SUPPLEMENTAL FIRM POWER</b>	<b>Summer</b>	<b>Winter</b>
Customer Charge \$/Bill	\$450.00	
Meter Charge \$/meter in addition to the first meter per delivery point	\$50.00	
Demand Charge Secondary \$/kW of SUPPLEMENTAL BILLING DEMAND	\$17.75	
Facilities Charge Secondary \$/kW of DELIVERED DEMAND	\$7.42	
Demand Charge Primary \$/kW of SUPPLEMENTAL BILLING DEMAND	\$17.25	
Facilities Charge Primary \$/kW of DELIVERED DEMAND	\$5.90	
Energy Charge Secondary \$/kWh SUPPLEMENTAL ENERGY	\$0.0255	\$0.0245
Energy Charge Primary \$/kWh SUPPLEMENTAL ENERGY	\$0.0242	\$0.0235
Excess kVAR Charge \$/kVAR for all EXCESS kVARs	\$2.60	
Dual Primary Service Charge \$/kW of DUAL PRIMARY DELIVERED DEMAND	\$3.50	

**WAPA DISTRIBUTION ENERGY LOSSES:** Shall be the arithmetic sum of the CUSTOMER’S entitled WAPA energy multiplied by the Distribution Energy Loss factor of 3%. These losses shall be billed at the applicable Supplemental Firm Power Energy Charge Rate.

**MAXIMUM SUPPLEMENTAL DEMAND:** Shall be the arithmetic sum of all metering points highest coincident integrated kilowatt load that is over and above the CUSTOMER’S entitled WAPA power and, if applicable the CUSTOMER’S generation power output, at the point(s) of metering during any 30-minute interval occurring in the BILLING PERIOD.

**SUPPLEMENTAL BILLING DEMAND:** Shall be either (a) or (b), whichever is higher:

- (a) The MAXIMUM SUPPLEMENTAL DEMAND occurring during the BILLING PERIOD.
- (b) 65% of the MAXIMUM SUPPLEMENTAL DEMAND established for the BILLS rendered for June, July, August or September of the preceding 11 months.

**MAXIMUM DEMAND:** The highest integrated kilowatt load on a delivery point during any 30-minute period occurring in the BILLING PERIOD for which the determination is made.

**DELIVERED DEMAND:** For each delivery point, either (a) or (b), whichever is higher:

- (a) The MAXIMUM DEMAND occurring during the BILLING PERIOD.
- (b) 65% of the highest MAXIMUM DEMAND established for the BILLS rendered for June, July, August or September of the preceding 11 months.

## **SUPPLEMENTAL FIRM POWER – 61 (Secondary) & 62 (Primary)**

**SUPPLEMENTAL ENERGY:** Shall be the sum of all kilowatt-hours over and above the WAPA energy entitlement and, if applicable, the CUSTOMER'S generation output, at the point(s) of metering.

**DUAL PRIMARY DEMAND:** Either (a) or (b), whichever is applicable:

- (a) Full service: When both primary services are adequate for the CUSTOMER'S entire load, DUAL PRIMARY DEMAND will be the DELIVERED DEMAND.
- (b) Partial service: When one of the primary services is only adequate for part of the CUSTOMER'S load, DUAL PRIMARY DEMAND will be either (1), (2) or (3), whichever is higher:
  - 1. The CUSTOMER requested kilowatt capacity of the DUAL PRIMARY SERVICE providing partial service.
  - 2. The MAXIMUM DEMAND during the BILLING PERIOD of the DUAL PRIMARY SERVICE providing partial service.
  - 3. 100 percent of the highest MAXIMUM DEMAND of the preceding 11 months of the DUAL PRIMARY SERVICE providing partial service.

**EXCESS KVARs:** Maximum kVARs for the BILLING PERIOD minus the product of the MAXIMUM DEMAND for the BILLING PERIOD multiplied by .39523 (representing a power factor of 93 percent). The CUSTOMER will be responsible for limiting kVAR requirements at or below this calculated level at all times and will be charged for EXCESS kVARs.

**PRIMARY VOLTAGE DELIVERY:** Where the CUSTOMER takes service and is metered at an available LES standard primary distribution voltage of either 7,200/12,470 volts three phase, four wire or 34,500 volts three phase, three wire; and the CUSTOMER owns, operates and maintains all voltage transformation and other distribution equipment past the primary meter.

**TRANSMISSION VOLTAGE DELIVERY:** Where the Customer takes service and is metered at an available system transmission voltage at or above 50,000 volts.

## **SUPPLEMENTAL FIRM POWER – 61 (Secondary) & 62 (Primary)**

### **TERMS AND CONDITIONS:**

1. Unless expressly modified by Agreement or Contract, service will be furnished subject to LES' Policies and Service Regulations. Dual Primary Service and other special service arrangements will be handled as a provision in the appropriate supplemental contracts.
2. TERMS OF PAYMENT - BILLS are due in full 23 days after rendered. LES may, in its discretion, require prepayment for services, render bills on a more frequent basis and require payment on a more frequent basis. Additionally, LES may require payments to be made using electronic means (wire, ACH). Any past due amounts are subject to the LES Policy – Termination of Electric Service and applicable Service Fees. Charges are subject to all applicable State and Local sales tax.
3. FLUCTUATING LOADS AND HARMONICS - CUSTOMERS operating equipment causing harmonic currents and/or highly fluctuating or large instantaneous demands, including, but not limited to, variable speed drives, motor starting, welders and x-ray machines, shall be required to pay all nonbetterment costs of corrective action required to maintain acceptable service quality to the CUSTOMER and not interfere with service on LES' lines or to other CUSTOMERS. See System Disturbances and Service Disruptions, and Disconnection of Electric Service in the Service Regulations.
4. COGENERATION OR SMALL POWER PRODUCTION - Refer to Customer-Owned Generation in the Service Regulations.

**Schedule TF - Transmission Facilities 33**

**AVAILABLE:** Only under contract for use of LES-owned transmission facilities.

**APPLICABLE:** For Western Area Power Administration (WAPA) Preference Customers who contract to use the LES interconnected transmission system. The minimum length of the contract shall be for one year and cancelable with one-year notice.

**TERM:** This schedule shall be effective August 1, 2018 and shall remain in effect until such time that it is superseded. The cost to provide service under this schedule can be reviewed by LES and is subject to change.

**CHARACTER OF SERVICE:** For WAPA power and energy deliveries utilizing the existing transmission and distribution network owned and operated by LES or approved extensions thereof at the designated Point(s) of Delivery.

**BILL:** Transmission Facilities Charge + Transmission Losses +All Credits or Charges (if applicable), based on the CHARGES in effect, the LES' Service Regulations, and all contractual agreements.

**BILLING PERIOD:** BILLS are rendered on a calendar-month basis or a date agreeable with LES for final readings.

**RATE:**

TRANSMISSION FACILITIES	Rate
Transmission Facilities Charge \$/kW of WAPA Demand	\$5.25

**WAPA DEMAND:** The pre-arranged amount of WAPA power for the BILLING PERIOD.

**CREDITS OR CHARGES:** Where the CUSTOMER has a WAPA allocation and LES is receiving payment from an agent for wheeling the CUSTOMER'S WAPA power and energy or LES is making payment to an agent for wheeling the CUSTOMER'S WAPA power and energy, the appropriate credit or charge shall be applied to the CUSTOMER'S BILL.

**TRANSMISSION LOSSES:** Power and energy losses associated with Delivery over the interconnected transmission and distribution system from LES point of receipt to the LES Point(s) of Delivery to the CUSTOMER shall be determined for the prior year and applied to the BILL evenly over the current calendar year.

### **Schedule TF - Transmission Facilities 33**

#### **TERMS AND CONDITIONS:**

1. Unless expressly modified by Agreement or Contract, service will be furnished subject to LES' Policies and Service Regulations.
2. TERMS OF PAYMENT - BILLS are due in full 23 days after rendered. Any past due amounts are subject to the LES Policy – Termination of Electric Service and applicable Service Fees. Charges are subject to all applicable State and Local sales tax.
3. FLUCTUATING LOADS AND HARMONICS - CUSTOMERS operating equipment causing harmonic currents and/or highly fluctuating or large instantaneous demands, including, but not limited to, variable speed drives, motor starting, welders and x-ray machines, shall be required to pay all non-betterment costs of corrective action required to maintain acceptable service quality to the CUSTOMER and not interfere with service on LES' lines or to other CUSTOMERS. See System Disturbances and Service Disruptions, and Disconnection of Electric Service in the Service Regulations.
4. COGENERATION OR SMALL POWER PRODUCTION -Refer to Customer-Owned Generation in the Service Regulations.

**Schedule Cogen – COGENERATION - 35 kV  
42 (Backup & Supplemental)**

**AVAILABLE:** Within Lincoln, Nebraska, and the LES Service Area.

**APPLICABLE:** A CUSTOMER under contract will receive service on this schedule as part of a contract for electric service if all of the following conditions are met:

- (a) The CUSTOMER has generation facilities of at least 100 kW<sub>AC</sub> that maintain qualifying generation facilities status pursuant to Public Utility Regulatory Policies Act of 1978 (PURPA) and Federal Energy Regulatory Commission (FERC) regulations. See <https://www.ecfr.gov/current/title-18/part-292>
- (b) The CUSTOMER'S generation facilities operate in parallel to LES' generation facilities.
- (c) The CUSTOMER and LES have entered into an interconnection agreement covering the CUSTOMER'S generating facilities for which supplemental and backup power is being requested.

**CHARACTER OF SERVICE:** For power and energy deliveries through an LES-owned meter at 60 Hertz to the CUSTOMER within LES' available capacity. Supplemental power and energy shall be the power and energy required by the CUSTOMER over and above power and energy provided by the CUSTOMER'S generation, at the designated Point of Delivery.

**BILL:** Customer Charge + Demand Charge (Backup and Supplemental) + Facilities Charge + Energy Charge (Backup and Supplemental) + Excess kVAR Charge (if applicable) + All Riders (if applicable) + Service Fees (if applicable) + City Dividend for Utility Ownership + Sales Tax (if applicable); based on the RATE in effect, LES' Service Regulations, and all contractual agreements (as applicable).

**BILLING PERIOD:** BILLS are rendered on a calendar-month basis or a date agreeable with LES for final readings.

### Schedule Cogen – COGENERATION - 35 kV 42 (Backup & Supplemental)

**DEFINITIONS:** The following definitions are applicable to this schedule and some refer to the metering diagram below.

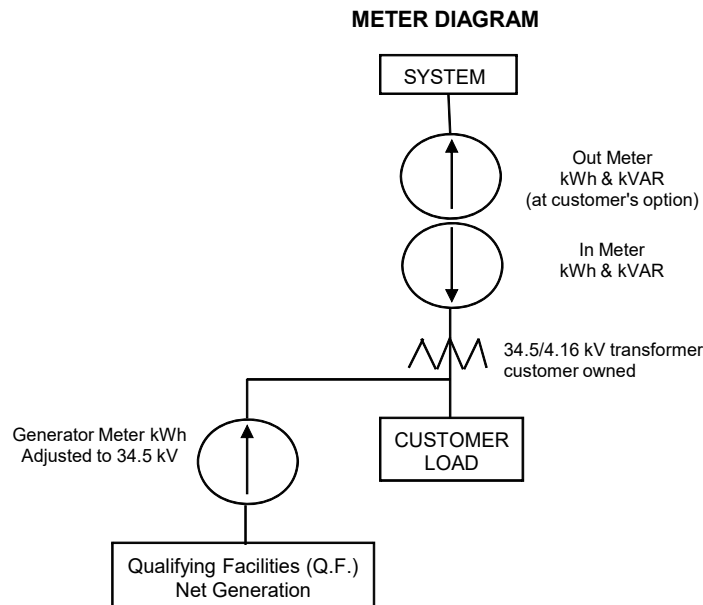

All meters are detented so only power flowing in the indicated direction is measured. Generator Meter readings are multiplied by 1.003 to bring them to the same voltage as the In Meter.

- **Backup Power-Demand:** The integrated kilowatt load during each 30-minute period as measured by the lower of (a) the In Meter, or (b) the Contract Demand minus the Generator Meter, but not less than zero.
- **Backup Power-Energy:** The sum of the 30-minute Backup Power-Demand over the total BILLING PERIOD in kilowatt-hours as measured by the In Meter and the Generator Meter, all divided by two (divided by two since there will be two readings per hour).
- **Contract Demand:** The contract capacity specified in Exhibit A of the applicable Qualifying Facility Cogeneration and Interconnection Agreement. This quantity is approximately equal to the maximum net generating capability of the CUSTOMER's qualifying facility in kilowatts as recorded by the Generator Meter. This amount shall apply for a minimum of twelve (12) consecutive months.
- **On-Peak Period:** The period occurring between the hours of 10:00 a.m. and 10:00 p.m. in the BILLING PERIOD.

**Schedule Cogen – COGENERATION - 35 kV  
42 (Backup & Supplemental)**

- **Qualifying Facility-Demand:** The integrated kilowatt output of the CUSTOMER's generator during 30-minute periods as measured by the Generator Meter minus the Out Meter. If there is no Out Meter, the Out Meter reading will be zero. Depending on how the CUSTOMER's generation support equipment is connected, the Qualifying Facility-Demand may be either gross or net generator output.
- **Qualifying Facility-Energy:** The sum of the 30-minute Qualifying Facility-Demand over the total BILLING PERIOD in kilowatt-hours as measured by the Generator Meter, all divided by two.
- **Supplemental Power-Demand:** The integrated kilowatt load during 30-minute periods as measured by the In Meter plus the Generator Meter minus the Contract Demand, but not less than zero.
- **Supplemental Power-Demand Delivered:** The integrated kilowatt load during 30-minute periods as measured by the lower of (a) the In Meter, or (b) the In Meter plus the Generator Meter minus the Contract Demand, but not less than zero.
- **Supplemental Power-Energy:** The sum of the 30-minute Supplemental Power-Demand Delivered over the total BILLING PERIOD in kilowatt-hours, all divided by two (divided by two since there will be two readings per hour).
- **Total Customer Demand:** The integrated kilowatt load during 30-minute periods as measured by the In Meter plus the Generator Meter minus the Out Meter. If there is no Out Meter, the Out Meter reading will be zero.

**SEASONAL PROVISION:** Summer and winter periods are defined as:

Summer – The four-month period from June 1 through September 30

Winter – The eight-month period from October 1 through May 31

**Schedule Cogen – COGENERATION - 35 kV  
 42 (Backup & Supplemental)**

**RATE:**

<b>COGENERATION</b>	<b>Summer</b>	<b>Winter</b>
Customer Charge Backup Power \$/BILL	\$450.00	
Demand Charge Backup Power \$/kW Higher of (a) or (b)		
(a) Maximum Backup Power-Demand during the On-Peak Period multiplied by the Backup Demand Charge + Backup Facilities Charge	\$15.30	
(b) Contract Demand multiplied by the Contract Demand Charge + Contract Facilities Charge	\$6.95	
Facilities Charge Backup Power \$/kW Higher of (a) or (b)		
(a) Maximum Backup Power-Demand during the On-Peak Period multiplied by the Backup Demand Charge + Backup Facilities Charge	\$2.40	
(b) Contract Demand multiplied by the Contract Demand Charge + Contract Facilities Charge	\$2.40	
Demand Charge Supplemental Power \$/kW Higher of (a) or (b) (a) the maximum Supplemental Power-Demand occurring during the BILLING PERIOD (b) 65% of the highest Supplemental Power-Demand established during June, July, August or September of the preceding 11 months	\$17.25	
Facilities Charge Supplemental Power \$/kW Higher of (a) or (b) (a) the maximum Supplemental Power-Demand occurring during the BILLING PERIOD (b) 65% of the highest Supplemental Power-Demand established during June, July, August or September of the preceding 11 months	\$2.40	
Energy Charge Backup Power \$/kWh	\$0.0242	\$0.0235
Energy Charge Supplemental Power \$/kWh	\$0.0242	\$0.0235
Excess kVAR Charge \$/kVAR for all EXCESS kVARs	\$2.60	

**MAINTENANCE ALLOWANCE:** Up to five (5) separate planned maintenance outages totaling no greater than 30 days per year may be allowed by LES when proper advanced notice and approval is given for each maintenance period. During these scheduled maintenance periods, the **Backup Power-Demand** charge will be waived for the purpose of allowing maintenance of the CUSTOMER’S generation. The procedures and conditions of the maintenance period shall be those set out in the applicable Qualifying Facility Cogeneration and Interconnection Agreement between the CUSTOMER and LES.

**Schedule Cogen – COGENERATION - 35 kV  
42 (Backup & Supplemental)**

**EXCESS kVARS:** All kVARS in excess of the maximum kW demand for **Supplemental, Backup and Maintenance Power** measured by meter M2 for the BILLING PERIOD multiplied by .39523 (representing a power factor of 93 percent).

The CUSTOMER is responsible for maintaining a power factor of not less than 93 percent leading or lagging at all times and will be charged for EXCESS kVARS.

**35 kV PRIMARY VOLTAGE DELIVERY:** Where the CUSTOMER takes service and is metered at the LES nominal voltage of 35,000 volts three phase, three wire; and the CUSTOMER owns, operates and maintains all voltage transformation and other distribution equipment past the primary meter.

**TERMS AND CONDITIONS:**

1. Unless expressly modified by Agreement or Contract, the terms and conditions of LES' policies and Service Regulations shall apply.
2. TERMS OF PAYMENT - BILLS on active accounts are due in full 23 days after rendered. LES may, in its discretion, require prepayment for services, render bills on a more frequent basis and require payment on a more frequent basis. Additionally, LES may require payments to be made using electronic means (wire, ACH). BILLS on final accounts are due upon receipt or the date of the most recently issued BILL, whichever is later. Any past due amounts are subject to LES policies regarding termination of electric service and applicable Service Fees. Charges are subject to all applicable State and Local sales tax.
3. FLUCTUATING LOADS AND HARMONICS – CUSTOMERs operating equipment causing harmonic currents and/or highly fluctuating or large instantaneous demands, including, but not limited to, variable speed drives, motor starting, welders and x-ray machines, shall be required to pay all nonbetterment costs of corrective action required to maintain acceptable service quality to the CUSTOMER and not interfere with service on LES' lines or to other CUSTOMERS. See System Disturbances and Service Disruptions, and Disconnection of Electric Service in the Service Regulations.
4. LOAD INCREASE MAXIMUMS - For equipment testing or other conditions producing abnormal increases in BILLING DEMANDS see Special Billing Considerations in the Service Regulations.
5. COGENERATION OR SMALL POWER PRODUCTION - Refer to Customer-Owned Generation in the Service Regulations.

**Schedule LPC – LARGE POWER CUSTOMER  
44 (Secondary), 45 (Primary), & 46 (35 kV)**

*The LPC rate will be closed to new customers beginning January 1<sup>st</sup>, 2026. The rate will be discontinued no later than January 1<sup>st</sup>, 2027*

**AVAILABLE:** Within Lincoln, Nebraska, and the LES Service Area.

**APPLICABLE:** A CUSTOMER will receive service on this schedule if any of the following conditions are met:

- (a) Energy usage is greater than 100,000 kWh per BILLING PERIOD for each of nine consecutive BILLING PERIODS.
- (b) The CUSTOMER'S demand is at minimum of 4,000 kW but less than 20,000 kW.
- (c) For new CUSTOMER accounts added to LES, usage and demand projections will be prepared by LES' Energy Delivery Division and the account will be placed on the appropriate schedule.

Removal from the LPC to the LLP schedule will take place if the account demonstrates in the previous 12 BILLING PERIODS no BILLING DEMAND greater than 4,000 kW per BILLING PERIOD for nine consecutive BILLING PERIODS.

Removal from the LPC to the GSD schedule will take place if the account demonstrates in the previous 12 BILLING PERIODS no BILLING DEMAND greater than 400 kW and no energy usage greater than 100,000 kWh per BILLING PERIOD for nine consecutive BILLING PERIODS.

Accounts are required to stay on a rate schedule for a minimum of 12 months.

**CHARACTER OF SERVICE:** Three-phase, 60 Hertz alternating current, supplied at LES' standard voltages through an LES-owned meter.

**BILL:** Customer Charge + Demand Charge + Facilities Charge + Energy Charge + Dual Primary Service Charge (if applicable) + Excess kVAR Charge (if applicable) + All Riders (if applicable) + Service Fees (if applicable) + City Dividend for Utility Ownership + Sales Tax (if applicable); based on the RATE in effect and LES' Service Regulations.

**BILLING PERIOD:** BILLS are rendered on a calendar-month basis or a date agreeable with LES for final readings.

**SEASONAL PROVISION:** Summer and winter periods are defined as:

Summer – The four-month period from June 1 through September 30

Winter – The eight-month period from October 1 through May 31

**Schedule LPC – LARGE POWER CUSTOMER  
 44 (Secondary), 45 (Primary), & 46 (35 kV)**

*The LPC rate will be closed to new customers beginning January 1<sup>st</sup>, 2026. The rate will be discontinued no later than January 1<sup>st</sup>, 2027*

**RATE:**

<b>LARGE POWER CUSTOMER</b>	<b>Summer</b>	<b>Winter</b>
Customer Charge \$/Bill Secondary	\$550.00	
Customer Charge \$/BILL Primary and 35 kV	\$550.00	
Demand Charge Secondary \$/kW of BILLING DEMAND	\$18.00	
Facilities Charge Secondary \$/kW of BILLING DEMAND	\$7.25	
Demand Charge Primary \$/kW of BILLING DEMAND	\$17.30	
Facilities Charge Primary \$/kW of BILLING DEMAND	\$6.80	
Demand Charge 35 kV \$/kW of BILLING DEMAND	\$17.30	
Facilities Charge 35 kV \$/kW of BILLING DEMAND	\$2.70	
Energy Charge Secondary \$/kWh	\$0.0265	\$0.0255
Energy Charge Primary and 35 kV \$/kWh	\$0.0260	\$0.0250
Excess kVAR Charge \$/kVAR for all EXCESS kVARs	\$2.60	
Dual Primary Service Charge \$/kW of DUAL PRIMARY DEMAND	\$6.50	

**MAXIMUM DEMAND:** The highest integrated kilowatt load during any 30-minute period occurring in the BILLING PERIOD for which the determination is made.

**BILLING DEMAND:** Either (a), (b) or (c), whichever is higher:

- (a) The MAXIMUM DEMAND occurring during the BILLING PERIOD.
- (b) 65 percent of the highest MAXIMUM DEMAND established for the BILLS rendered for June, July, August or September of the preceding 11 months.
- (c) 4,000 kW.

**PRIMARY VOLTAGE DELIVERY:** Where the CUSTOMER takes service and is metered at an available LES standard primary distribution voltage of either 7,200/12,470 volts three phase, four wire or 34,500 volts three phase, three wire; and the CUSTOMER owns, operates and maintains all voltage transformation and other distribution equipment past the primary meter.

**DUAL PRIMARY SERVICE:** When LES provides capacity from two primary service sources and where the CUSTOMER controls the switchgear transferring load between the two primary service sources. One of the services may be sufficient to serve part of the CUSTOMER'S load, but not all of the load. The CUSTOMER controlled switchgear shall have either a break before make transfer switch or two keyed interlock single throw switches within the same lineup to prevent paralleling of the two primary service sources. LES may also require Aid-to-Construction payments for the dual service installation.

**Schedule LPC – LARGE POWER CUSTOMER  
44 (Secondary), 45 (Primary), & 46 (35 kV)**

*The LPC rate will be closed to new customers beginning January 1<sup>st</sup>, 2026. The rate will be discontinued no later than January 1<sup>st</sup>, 2027*

**DUAL PRIMARY DEMAND:** Either (a) or (b), whichever is applicable:

- (a) Full service: When both primary services are adequate for the CUSTOMER'S entire load, DUAL PRIMARY DEMAND will be the BILLING DEMAND.
- (b) Partial service: When one of the primary services is only adequate for part of the CUSTOMER'S load, DUAL PRIMARY DEMAND will be either (1), (2) or (3), whichever is higher:
  - (1) The CUSTOMER requested kilowatt capacity of the DUAL PRIMARY SERVICE providing partial service.
  - (2) The MAXIMUM DEMAND during the BILLING PERIOD of the DUAL PRIMARY SERVICE providing partial service.
  - (3) 100 percent of the highest MAXIMUM DEMAND of the preceding 11 months of the DUAL PRIMARY SERVICE providing partial service.

**EXCESS kVARS:** Maximum kVARS for the BILLING PERIOD minus the product of the MAXIMUM DEMAND for the BILLING PERIOD multiplied by .39523 (representing a power factor of 93 percent). The CUSTOMER will be responsible for limiting kVAR requirements at or below this calculated level at all times and will be charged for EXCESS kVARS.

**TERMS AND CONDITIONS:**

1. Service will be furnished subject to LES' policies and Service Regulations.
2. TERMS OF PAYMENT - BILLS on active accounts are due in full 23 days after rendered. LES may, in its discretion, require prepayment for services, render bills on a more frequent basis and require payment on a more frequent basis. Additionally, LES may require payments to be made using electronic means (wire, ACH). BILLS on final accounts are due upon receipt or the date of the most recently issued BILL, whichever is later. Any past due amounts are subject to LES policies regarding termination of electric service and applicable Service Fees. Charges are subject to all applicable State and Local sales tax.
3. FLUCTUATING LOADS AND HARMONICS – CUSTOMERs operating equipment causing harmonic currents and/or highly fluctuating or large instantaneous demands, including, but not limited to, variable speed drives, motor starting, welders and X-ray machines, shall be required to pay all nonbetterment costs of corrective action required to maintain acceptable service quality to the CUSTOMER and not interfere with service on LES' lines or to other CUSTOMERS. See System Disturbances and Service Disruptions, and Disconnection of Electric Service in the Service Regulations.
4. COGENERATION OR SMALL POWER PRODUCTION - Refer to Customer-Owned Generation in the Service Regulations.

**Schedule LPC-OPD – LARGE POWER CUSTOMER – OFF-PEAK DAILY  
47 (Secondary), 48 (Primary) & 49 (35 kV)**

*The LPC-OPD rate will be closed to new customers beginning January 1<sup>st</sup>, 2026. The rate will be discontinued no later than January 1<sup>st</sup>, 2027*

**AVAILABLE:** Within Lincoln, Nebraska, and the LES Service Area.

**APPLICABLE:** A CUSTOMER may receive service on this schedule if any of the following conditions are met:

- (a) Energy usage is greater than 100,000 kWh per BILLING PERIOD for each of nine consecutive BILLING PERIODS.
- (b) The CUSTOMER'S demand is at minimum of 4,000 kW but less than 20,000 kW.
- (c) For new CUSTOMER accounts added to LES, usage and demand projections will be prepared by LES' Energy Delivery Division and the account will be placed on the appropriate schedule.

Removal from this schedule to another applicable LLP schedule may take place after a minimum of one year on this schedule.

Removal from the LPC to the LLP schedule will take place if the account demonstrates in the previous 12 BILLING PERIODS no BILLING DEMAND greater than 4,000 kW per BILLING PERIOD for nine consecutive BILLING PERIODS.

Removal from the LPC to the GSD schedule will take place if the account demonstrates in the previous 12 BILLING PERIODS no BILLING DEMAND greater than 400 kW and no energy usage greater than 100,000 kWh per BILLING PERIOD for nine consecutive BILLING PERIODS.

Accounts are required to stay on a rate schedule for a minimum of 12 months.

**CHARACTER OF SERVICE:** Three-phase, 60 Hertz alternating current, supplied at LES' standard voltages through an LES-owned meter.

**BILL:** Customer Charge + Demand Charge + Facilities Charge + Energy Charge + Dual Primary Service Charge (if applicable) + Excess kVAR Charge (if applicable) + All Riders (if applicable) + Service Fees (if applicable) + City Dividend for Utility Ownership + Sales Tax (if applicable); based on the RATE in effect and LES' Service Regulations.

**BILLING PERIOD:** BILLS are rendered on a calendar-month basis or a date agreeable with LES for final readings.

**SEASONAL PROVISION:** Summer and winter periods are defined as:

- Summer – The four-month period from June 1 through September 30
- Winter – The eight-month period from October 1 through May 31

**Schedule LPC-OPD – LARGE POWER CUSTOMER – OFF-PEAK DAILY  
 47 (Secondary), 48 (Primary) & 49 (35 kV)**

*The LPC-OPD rate will be closed to new customers beginning January 1<sup>st</sup>, 2026. The rate will be discontinued no later than January 1<sup>st</sup>, 2027*

**RATE:**

<b>LARGE POWER CUSTOMER OFF-PEAK DAILY</b>		<b>Summer</b>	<b>Winter</b>
Customer Charge \$/BILL		\$550.00	
Demand Charge Secondary \$/kW of SUMMER BASE BILLING DEMAND		\$18.00	
PLUS Demand Charge Secondary \$/kW of OFF-PEAK EXCESS BILLING DEMAND		\$7.00	
Facilities Charge Secondary \$/kW of SUMMER BASE BILLING DEMAND		\$7.25	
PLUS Facilities Charge Secondary \$/kW of OFF-PEAK EXCESS BILLING DEMAND		\$7.25	
Demand Charge Primary \$/kW of SUMMER BASE BILLING DEMAND		\$17.30	
PLUS Demand Charge Primary \$/kW of OFF-PEAK EXCESS BILLING DEMAND		\$6.80	
Facilities Charge Primary \$/kW of SUMMER BASE BILLING DEMAND		\$6.80	
PLUS Facilities Charge Primary \$/kW of OFF-PEAK EXCESS BILLING DEMAND		\$6.80	
Demand Charge 35 kV \$/kW of SUMMER BASE BILLING DEMAND		\$17.30	
PLUS Demand Charge 35 kV \$/kW of OFF-PEAK EXCESS BILLING DEMAND		\$6.70	
Facilities Charge 35 kV \$/kW of SUMMER BASE BILLING DEMAND		\$2.55	
PLUS Facilities Charge 35 kV \$/kW of OFF-PEAK EXCESS BILLING DEMAND		\$2.55	
Energy Charge Secondary \$/kWh		\$0.0265	\$0.0255
Energy Charge Primary and 35 kV \$/kWh		\$0.0260	\$0.0250
Excess kVAR Charge \$/kVAR for all EXCESS kVARs		\$2.60	
Dual Primary Service Charge \$/kW of DUAL PRIMARY DEMAND		\$6.50	

**MAXIMUM DEMAND:** The highest integrated kilowatt load during any 30-minute period occurring in the BILLING PERIOD for which the determination is made.

**Schedule LPC-OPD – LARGE POWER CUSTOMER – OFF-PEAK DAILY  
47 (Secondary), 48 (Primary) & 49 (35 kV)**

*The LPC-OPD rate will be closed to new customers beginning January 1<sup>st</sup>, 2026. The rate will be discontinued no later than January 1<sup>st</sup>, 2027*

**SUMMER ON-PEAK PERIOD:** The SUMMER ON-PEAK PERIOD is every weekday (Monday through Friday) between 2 p.m. and 8 p.m. (daylight saving time) in the SUMMER BILLING PERIODS as recorded by LES' billing meters. Weekend days (Saturday and Sunday) and weekday observations (Federal Holiday designation) of Independence Day and Labor Day are not in the SUMMER ON-PEAK PERIOD.

**SUMMER BASE BILLING DEMAND:** Shall be (a) below unless the current billing is for a summer month; then the SUMMER BASE BILLING DEMAND shall be the greater of (a) or (b) below:

- (a) 100 percent of the MAXIMUM DEMAND occurring during the SUMMER ON-PEAK PERIOD established for the BILLS rendered for June, July, August or September of the preceding 11 months.
- (b) The MAXIMUM DEMAND occurring during the SUMMER ON-PEAK PERIOD of the current summer BILLING PERIOD.

**OFF-PEAK EXCESS BILLING DEMAND:** Either (a) or (b), whichever is higher:

- (a) The current month's MAXIMUM DEMAND minus the SUMMER BASE BILLING DEMAND. Should the SUMMER BASE BILLING DEMAND be greater than the current BILLING PERIOD'S MAXIMUM DEMAND, the OFF-PEAK EXCESS BILLING DEMAND will be zero.
- (b) 4,000 kW minus the SUMMER BASE BILLING DEMAND, but not less than zero.

**BILLING DEMAND:** Either (a) or (b), whichever is higher:

- (a) The MAXIMUM DEMAND occurring during the BILLING PERIOD.
- (b) SUMMER BASE BILLING DEMAND.

**PRIMARY VOLTAGE DELIVERY:** Where the CUSTOMER takes service and is metered at an available LES standard primary distribution voltage of either 7,200/12,470 volts three phase, four wire or 34,500 volts three phase, three wire; and the CUSTOMER owns, operates and maintains all voltage transformation and other distribution equipment past the primary meter.

**DUAL PRIMARY SERVICE:** When LES provides capacity from two primary service sources and where the CUSTOMER controls the switchgear transferring load between the two primary service sources. One of the services may be sufficient to serve part of the CUSTOMER'S load, but not all of the load. The CUSTOMER controlled switchgear shall have either a break before make transfer switch or two keyed interlock single throw switches within the same lineup to prevent paralleling of the two primary service sources. LES may also require Aid-to-Construction payments for the dual service installation.

**DUAL PRIMARY DEMAND:** Either (a) or (b), whichever is applicable:

- (a) Full service: When both primary services are adequate for the CUSTOMER'S entire load, DUAL PRIMARY DEMAND will be the BILLING DEMAND.

**Schedule LPC-OPD – LARGE POWER CUSTOMER – OFF-PEAK DAILY  
47 (Secondary), 48 (Primary) & 49 (35 kV)**

*The LPC-OPD rate will be closed to new customers beginning January 1<sup>st</sup>, 2026. The rate will be discontinued no later than January 1<sup>st</sup>, 2027*

- (b) Partial service: When one of the primary services is only adequate for part of the CUSTOMER'S load, DUAL PRIMARY DEMAND will be either (1), (2) or (3), whichever is higher:
- (1) The CUSTOMER requested kilowatt capacity of the DUAL PRIMARY SERVICE providing partial service.
  - (2) The MAXIMUM DEMAND during the BILLING PERIOD of the DUAL PRIMARY SERVICE providing partial service.
  - (3) 100 percent of the highest MAXIMUM DEMAND of the preceding 11 months of the DUAL PRIMARY SERVICE providing partial service.

**EXCESS kVARS:** Maximum kVARS for the BILLING PERIOD minus the product of the MAXIMUM DEMAND for the BILLING PERIOD multiplied by .39523 (representing a power factor of 93 percent). The CUSTOMER will be responsible for limiting kVAR requirements at or below this calculated level at all times and will be charged for EXCESS kVARS.

**TERMS AND CONDITIONS:**

1. Service will be furnished subject to LES' policies and Service Regulations.
2. TERMS OF PAYMENT - BILLS on active accounts are due in full 23 days after rendered. LES may, in its discretion, require prepayment for services, render bills on a more frequent basis and require payment on a more frequent basis. Additionally, LES may require payments to be made using electronic means (wire, ACH). BILLS on final accounts are due upon receipt or the date of the most recently issued BILL, whichever is later. Any past due amounts are subject to LES policies regarding termination of electric service and applicable Service Fees. Charges are subject to all applicable State and Local sales tax.
3. FLUCTUATING LOADS AND HARMONICS – CUSTOMERs operating equipment causing harmonic currents and/or highly fluctuating or large instantaneous demands, including, but not limited to, variable speed drives, motor starting, welders and X-ray machines, shall be required to pay all nonbetterment costs of corrective action required to maintain acceptable service quality to the CUSTOMER and not interfere with service on LES' lines or to other CUSTOMERS. See System Disturbances and Service Disruptions, and Disconnection of Electric Service in the Service Regulations.
4. COGENERATION OR SMALL POWER PRODUCTION - Refer to Customer-Owned Generation in the Service Regulations.

**Schedule LP-M – LARGE POWER WITH MARKET ENERGY  
55 (115 kV)**

**AVAILABLE:** Within Lincoln, Nebraska, and the LES Service Area. Please contact LES to discuss geographic availability within the Service Area.

**APPLICABLE:** To CUSTOMERS within the LES Service Area which take service at 115 kV, served through a fully dedicated LES substation, and have a minimum of 20 MW BILLING DEMAND (or expected within the first 12 months of taking services from LES). LES may require customers on this rate to execute other agreements as applicable.

**CHARACTER OF SERVICE:** Three-phase, 60 Hertz alternating current, supplied at 115 kV through an LES-owned meter.

**UTILITY CHARGES:** Customer Charge + Demand Charge + Excess MVAR Charge (if applicable) + All Riders (if applicable) + Service Fees (if applicable) + Sales Tax (if applicable); based on the RATE in effect and LES’ Service Regulations.

**MARKET ENERGY CHARGES:** Market Energy Charge \* 1.05 for Payment in Lieu of Tax + City Dividend for Utility Ownership + Sales Tax (if applicable); based on the RATE in effect and LES’ Service Regulations.

**BILLING PERIOD:** UTILITY CHARGES are rendered on a calendar-month basis or a date agreeable with LES for final readings. MARKET ENERGY CHARGES are rendered on a weekly basis or a date agreeable with LES for final readings.

**RATE:**

<b>LARGE POWER WITH MARKET ENERGY</b>	<b>Rate</b>
Customer Charge \$/BILL	\$2,635.00
Demand Charge 115 kV \$/MW of BILLING DEMAND	\$18,900.00
Market Energy Charge	SPP Asset Owner Load Charges
Excess MVAR Charge \$/MVAR for all EXCESS MVARs	\$2,600.00

**MARKET ENERGY CHARGE:** LES will register the CUSTOMER load as an Asset Owner in SPP, for the purposes of billing. The energy charge will be the aggregate of all CUSTOMER-specific load related charges assessed by SPP in the applicable BILLING PERIOD. LES will notify the Customer of the SPP node used to price the energy and all applicable SPP charges.

**MAXIMUM DEMAND:** The highest integrated megawatt load during any 15-minute period occurring in the BILLING PERIOD for which the determination is made.

**Schedule LP-M – LARGE POWER WITH MARKET ENERGY  
55 (115 kV)**

**BILLING DEMAND:** Either (a), (b) or (c), whichever is higher:

- (a) The MAXIMUM DEMAND occurring during the BILLING PERIOD.
- (b) 65 percent of the highest MAXIMUM DEMAND established for the BILLS rendered for June, July, August or September of the preceding 11 months.
- (c) 20 MW.

**EXCESS MVARs:** The CUSTOMER will be responsible for limiting MVAR requirements at or below the calculated level below at all times and will be charged for EXCESS MVARs. If the EXCESS MVARs calculated by the formula below is equal to or less than 0, then no penalty will be charged.

$$EXCESS\ MVARs = MAXIMUM\ MVARs - \sqrt{MAXIMUM\ DEMAND^2 \left( \frac{1}{POWER\ FACTOR\ FROM\ SUPPLY\ AGREEMENT^2} - 1 \right)}$$

**TERMS AND CONDITIONS:**

1. Service will be furnished subject to LES' policies and Service Regulations.
2. TERMS OF PAYMENT – UTILITY CHARGES on active accounts are due in full 23 days after rendered. MARKET ENERGY CHARGES on active accounts are due in full seven days after rendered. LES may, in its discretion, require prepayment for services, render bills on a more frequent basis and require payment on a more frequent basis. Additionally, LES may require payments to be made using electronic means (wire, ACH). CUSTOMER is required to pay to LES the full amount due, regardless of CUSTOMER'S dispute of MARKET ENERGY CHARGES, due to such charges being a pass-through by LES from SPP. BILLS on final accounts are due upon receipt or the date of the most recently issued BILL, whichever is later. Any past due amounts are subject to LES policies regarding termination of electric service and applicable Service Fees. Charges are subject to all applicable State and Local sales tax.
3. FLUCTUATING LOADS AND HARMONICS – CUSTOMERs operating equipment causing harmonic currents and/or highly fluctuating or large instantaneous demands, including, but not limited to, variable speed drives, motor starting, welders and X-ray machines, shall be required to pay all nonbetterment costs of corrective action required to maintain acceptable service quality to the CUSTOMER and not interfere with service on LES' lines or to other CUSTOMERs. See System Disturbances and Service Disruptions, and Disconnection of Electric Service in the Service Regulations.
4. COGENERATION OR SMALL POWER PRODUCTION - Refer to Customer-Owned Generation in the Service Regulations.

**Schedule SEC LIGHT – SECURITY LIGHTING – 20**

**AVAILABLE:** Within Lincoln, Nebraska, and the LES Service Area.

**APPLICABLE:** To any CUSTOMER, to light an area of an existing meter service location agreeable to LES, for which LES-owned lamps with photocell dusk-to-dawn control will be installed on LES poles.

**CHARACTER OF SERVICE:** Single-phase, 60 Hertz alternating current, 120 volts, two wire, non-metered.

**BILL:** Applicable Security Lighting and Festoon Outlet Charges + Riders added on to the BILL of an existing metered account + Service Fees (if applicable) + Sales Tax (if applicable); based on the Schedule in effect and LES' Service Regulations.

**BILLING PERIOD:** Non-metered services BILLING PERIODS are based on a monthly schedule set by LES.

**RATE:**

Poles and Secondaries: Additional charges per BILLING PERIOD for poles and/or secondaries installed prior to January 1, 1979, for the operation of the lamp(s). Subsequent to January 1, 1979, LES discontinued pole installations. LES will maintain existing installations of poles and overhead/underground secondary. No poles or underground secondary will be installed for new installations.

Festoons: Outlets mounted on street light poles as per [Festoon Outlet Guidelines](#). For 120 V, 2 amp breaker.

<b>SECURITY LIGHTING</b>	<b>Rate</b>
Security Lighting Charge \$/lamp/BILLING PERIOD	
Mercury Vapor 175 Watt*	\$16.75
Mercury Vapor 250 Watt*	\$19.50
Mercury Vapor 400 Watt*	\$21.50
Mercury Vapor 1,000 Watt*	\$35.50
High Pressure Sodium Vapor 70 Watt*	\$15.50
High Pressure Sodium Vapor 150 Watt*	\$17.50
High Pressure Sodium Vapor 250 Watt*	\$19.50
Metal Halide 400 Watt*	\$24.50
LED Small	\$8.40
LED Medium	\$8.80
LED Large	\$9.94
Pole	\$2.75
OH Overhead Secondary span up to 150 feet	\$1.35
UG Underground Secondary	\$3.00
Festoon Photocell Outlet (\$/outlet)	\$0.97
Festoon Continuous Outlet (\$/lamp)	\$2.69

\*Only for existing installations - no new installations of these luminaires. Damaged or failed luminaires, beyond field repair, will be replaced with LED luminaires.

## **Schedule SEC LIGHT – SECURITY LIGHTING – 20**

### **TERMS AND CONDITIONS:**

1. Service will be furnished subject to LES' policies and Service Regulations.
2. TERMS OF PAYMENT - BILLS on active accounts are due in full 23 days after rendered. BILLS on final accounts are due upon receipt or the date of the most recently issued BILL, whichever is later. Any past due amounts are subject to LES policies regarding termination of electric service and applicable Service Fees. Charges are subject to all applicable State and Local sales tax.
3. Existing poles which have been provided prior to January 1, 1979, and replacement of such poles, shall not be used for any purposes other than the mounting of LES-owned security lamps.
4. All costs related to the installation of a Festoon Outlet will be paid by the CUSTOMER prior to installation. Installations will be made where feasible as determined by LES' Energy Delivery Division.
5. For Festoon Outlets, the CUSTOMER taking service shall indemnify, protect and save harmless LES and its officers, agents and employees, from and against any and all claims, demands, suits, judgments, liabilities, loss or damages, which may arise out of or be caused by erection, maintenance, presence, use or removal of their equipment.
6. Temporarily disconnected security lighting (at the CUSTOMER'S request), which is reconnected at a later date, will be subject to LES Service Fees and Disconnection of Electric Service in the Service Regulations. Lighting installations disconnected for more than 90 consecutive days shall be removed by LES.

**Schedule TRAF LIGHT – TRAFFIC LIGHTING SERVICE – 24**

**AVAILABLE:** Within Lincoln, Nebraska, and the LES Service Area.

**APPLICABLE:** For publicly-owned and maintained traffic lighting service which conforms to LES’ traffic lighting specifications pursuant to the terms and conditions of City of Lincoln Executive Order #42127. Public traffic signals (pre-timed, actuated or school crossing) are defined as a set of electrically operated signal lights to direct or control pedestrian and vehicular traffic on public streets. Traffic signals on private property and any other traffic control related equipment (message boards, communication amplifiers, etc.) shall be metered as a general service. Traffic cameras that are a component of a public intersection may be non-metered. All other cameras shall be metered and billed as General Service.

**CHARACTER OF SERVICE:** Single-phase, 60 Hertz alternating current, supplied at LES’ standard voltages on a non-metered service pursuant to agreements between the CUSTOMER and LES.

**BILL:** Energy & Facilities Charge + Capital Investment Charge (if applicable) + All Riders (if applicable) + Service Fees (if applicable) + City Dividend for Utility Ownership + Sales Tax (if applicable); based on the RATE in effect and LES’ Service Regulations.

**BILLING PERIOD:** Non-metered services BILLING PERIODS are based on a monthly schedule set by LES.

**RATE:**

TRAFFIC LIGHTING	Rate
Energy & Facilities Charge (\$/kWh)	\$0.0645

**CAPITAL INVESTMENT CHARGE:** 0.75 of one percent per BILLING PERIOD (9 percent per year) of the Traffic Light capital investment by LES for the prior 20-year period, plus 0.3 debt service coverage charge.

**MINIMUM BILL:** \$1.00

**TERMS AND CONDITIONS:**

1. Service will be furnished subject to LES’ policies and Service Regulations.
2. TERMS OF PAYMENT - BILLS on active accounts are due in full 23 days after rendered. BILLS on final accounts are due upon receipt or the date of the most recently issued BILL, whichever is later. Any past due amounts are subject to LES policies regarding termination of electric service and applicable Service Fees. Charges are subject to all applicable State and Local sales tax.
3. COGENERATION OR SMALL POWER PRODUCTION - Refer to Customer-Owned Generation in the Service Regulations.

**Schedule ST LIGHT – STREET LIGHTING SERVICE – 26**

**AVAILABLE:** Within Lincoln, Nebraska, and the LES Service Area.

**APPLICABLE:** To all public agencies for street lighting service which conforms to LES’ street lighting specifications. For lighting of vehicle accessible public streets and alleyways, and pedestrian/bike accessible tunnels under public streets. Street lights may be placed (if reasonable) on existing LES poles, joint use poles or City street light poles for the sole purpose of area lighting in public areas, upon agreement with the respective government agency and LES. All other lighting, for private property and City-owned property, shall be metered on another rate.

**CHARACTER OF SERVICE:** LES will provide photocell controlled energy at 60 Hertz to all lighting systems and will construct, operate and maintain those lighting systems pursuant to agreements between the CUSTOMER and LES.

**BILL:** Energy & Facilities Charge + Maintenance Charge (if applicable) + Capital Investment Charge (if applicable) + All Riders (if applicable) + Service Fees (if applicable) + City Dividend for Utility Ownership + Sales Tax (if applicable); based on the RATE in effect and LES’ Service Regulations.

**BILLING PERIOD:** Non-metered services BILLING PERIODS are based on a monthly schedule set by LES.

**RATE:**

<b>STREET LIGHTING</b>	<b>Rate</b>
Energy & Facilities Charge (\$/kWh)	\$0.0585
Maintenance Charge (\$/lamp/BILLING PERIOD)	
Mercury Vapor 175 Watt*	\$7.33
High Pressure Sodium Vapor 35 Watt - 400 Watt	\$7.33
High Pressure Sodium Vapor 1,000 Watt*	\$8.14
Metal Halide 70 Watt*	\$8.96
Metal Halide 100 Watt*	\$8.45
Metal Halide 175 Watt*	\$9.09
Metal Halide 250 Watt*	\$9.09
Metal Halide 400 Watt*	\$7.29
Metal Halide 1,000 Watt*	\$9.65
LED All Watts	\$6.80
Induction 23 Watt*	\$5.92

\*Only for existing installations.

**CAPITAL INVESTMENT CHARGE:** 0.75 of one percent per BILLING PERIOD (9 percent per year) of the Street Light capital investment by LES for the prior 20 year period, plus 0.3 debt coverage charge.

## **Schedule ST LIGHT – STREET LIGHTING SERVICE – 26**

### **TERMS AND CONDITIONS:**

1. Service will be furnished subject to LES' policies and Service Regulations.
2. **TERMS OF PAYMENT - BILLS** on active accounts are due in full 23 days after rendered. **BILLS** on final accounts are due upon receipt or the date of the most recently issued **BILL**, whichever is later. Any past due amounts are subject to LES policies regarding termination of electric service and applicable Service Fees. Charges are subject to all applicable State and Local sales tax.
3. **INVESTMENT IN EQUIPMENT** - LES shall install additional lighting units in any of the standard lamp sizes so long as the average life of said investment is estimated to be in excess of 20 years. Lighting not in conformance with these limits will be installed, if feasible. LES will either (a) bill the **CUSTOMER** for street light installations completed, or (b) bill the **CUSTOMER** the Capital Investment charge.
4. **COGENERATION OR SMALL POWER PRODUCTION** - Refer to Customer-Owned Generation in the Service Regulations.

**Schedule CURT – CURTAILMENT RIDER**

**AVAILABLE:** Within Lincoln, Nebraska, and the LES Service Area.

**APPLICABLE:** To any CUSTOMER not on the Interruptible Service Rider and taking service under the following LES rate schedules:

- Schedule LLP – Large Light & Power 15 (Secondary), 16 (Primary), & 39 (35 kV)
- Schedule LPC – Large Power Customer 44 (Secondary), 45 (Primary), & 46 (35 kV)
- Schedule Cogen – Cogeneration 42 (35 kV)
- Supplemental Firm Power Contracts

**CHARACTER OF SERVICE:** As identified under the applicable rate schedule.

**CURTAILED DEMAND:** The amount of demand the CUSTOMER curtails during an event.

**DEMAND:** The integrated kilowatt load during any 30-minute period.

**CURTAILMENT PAYMENT:** The payment made to the CUSTOMER for CURTAILED DEMAND during that summer period.

**CURTAILMENT PERIOD:** Any day during the summer period from 4 p.m. to 8 p.m. in which LES calls for curtailment.

**SEASONAL PROVISION:** Summer and winter periods are defined as:

- Summer – The four-month period from June 1 through September 30
- Winter – The eight-month period from October 1 through May 31

**RATE:** Following the summer period, LES will make a CURTAILMENT PAYMENT to the CUSTOMER based on the amount of CURTAILED DEMAND during the CURTAILMENT PERIODS.

- Once a CURTAILMENT PERIOD has occurred, LES will review the CUSTOMER meter data to determine the CURTAILED DEMAND.
- Upon the end of the summer season, LES will multiply the total CURTAILED DEMAND over all CURTAILMENT PERIODS by the rate to determine the CURTAILMENT PAYMENT.

<b>CURTAILMENT RIDER</b>	<b>Rate</b>
Curtailment Payment \$/kW of CURTAILED DEMAND	\$2.40

## **Schedule CURT – CURTAILMENT RIDER**

### **TERMS AND CONDITIONS:**

1. Service will be furnished subject to LES' policies and Service Regulations.
2. All applicable Terms and Conditions from the CUSTOMER's applicable rate schedule apply.
3. LES will notify CUSTOMERS by at least 9 am the morning of a CURTAILMENT PERIOD event.
4. There will be no more than 10 CURTAILMENT PERIOD events per summer period.
5. The CUSTOMER will furnish, install and maintain all equipment necessary to measure and provide curtailable capability. The CUSTOMER is responsible for all CUSTOMER equipment operation and maintenance. LES assumes no liability for the operation and maintenance of the CUSTOMER's equipment or for protection of any property or person associated with the CUSTOMER's business operation, and the CUSTOMER agrees to indemnify and hold LES harmless from any claim or liability resulting from the curtailable service to be provided pursuant to this rider or from any load curtailment request.

***Suspended as of 08/01/2023***

Sheet 1 of 2

**Schedule EDR – ECONOMIC DEVELOPMENT RIDER**

**AVAILABLE:** Within Lincoln, Nebraska, and the LES Service Area.

**APPLICABLE:** This EDR is a way to encourage business expansion and economic development in the LES Service Area. This EDR is available to CUSTOMERS who are eligible for the Imagine Nebraska Act and are being served under the following LES Rate Schedules:

Schedule LLP – Large Light & Power 15 (Secondary), 16 (Primary), 39 (35 kV) where service is available

Schedule LPC – Large Power Customer 44 (Secondary), 45 (Primary), 46 (35 kV) where service is available

Schedule LP-M – Large Power with Market Energy 55 (115 kV) where service is available

The provisions of the EDR are applicable to new CUSTOMERS and to existing CUSTOMERS adding a separately metered account on an applicable rate schedule. (See Terms & Conditions #6.)

In any billing period where the CUSTOMER'S load factor is equal to or greater than 55%, an EDR Credit will be calculated and applied to the CUSTOMER'S BILL.

Service under the EDR is conditional upon LES approval of an EDR Service Agreement and Attachment 1 (the "EDR Service Agreement").

**CHARACTER OF SERVICE:** As identified under the applicable rate schedule.

**RATE:** CUSTOMERS taking service under the EDR shall be served according to all the rates, terms, and conditions of the normally applicable rate schedule. "Demand Charge" (for purposes of this rider) includes any credits provided under any other demand applicable rider. Credits shall not apply to Customer, Facilities, Energy, Dual Service, or Excess kVAR charges. The contract years over which the EDR credits are applied are referred to as the "EDR Credit Period." Variations in these terms shall be permitted so long as the total term of the agreement is twice as long as the EDR Credit Period, with the EDR Credit Period not to exceed five (5) years (60 billing periods).

A CUSTOMER shall receive an EDR credit (the "EDR Credit") in any billing period where the CUSTOMER's load factor is equal to or greater than 55% and it will be determined as follows (unless otherwise agreed upon. See TERMS & CONDITIONS):

- a) for the twelve consecutive monthly billings of the first contract year, the EDR Credit shall be 50% of the Demand Charge;
- b) for the twelve consecutive monthly billings of the second contract year, the EDR Credit shall be 40% of the Demand Charge;
- c) for the twelve consecutive monthly billings of the third contract year, the EDR Credit shall be 30% of the Demand Charge;
- d) for the twelve consecutive monthly billings of the fourth contract year, the EDR Credit shall be 20% of the Demand Charge;
- e) for the twelve consecutive monthly billings of the fifth contract year, the EDR Credit shall be 10% of the Demand Charge; and
- f) all subsequent billings shall be at full charges stated in the applicable rate schedule.

***Suspended as of 08/01/2023***

Sheet 2 of 2

**Schedule EDR – ECONOMIC DEVELOPMENT RIDER**

**TERMS AND CONDITIONS:**

1. A signed EDR Service Agreement between LES and the CUSTOMER is required. The standard term of the EDR Service Agreement shall be ten (10) years (120 billing periods) and the standard EDR Credit Period shall be five (5) years (60 billing periods). An EDR Service Agreement can be obtained by contacting the Manager, Energy Services.
2. In accordance with the EDR Service Agreement, the CUSTOMER must deliver to LES a letter of credit, or other security deemed acceptable by LES, in an amount and format agreed upon by LES to cover the financial risk to LES associated with discontinuation of service by the CUSTOMER prior to the expiration of the EDR Service Agreement.
3. All applicable charges under the applicable rate schedule shall apply.
4. If at any time during the term of the EDR Service Agreement the CUSTOMER violates any of the terms and conditions of the EDR or the EDR Service Agreement, LES may discontinue service under this EDR without notice and bill the CUSTOMER under the applicable schedule without further credits or discounts. In the event electric service is terminated or discontinued under this EDR by the CUSTOMER or LES, the CUSTOMER shall pay LES, in addition to all other applicable charges, the sum of all EDR Credits received plus 5% for Payment in Lieu of Tax, net of any amount collected by LES through the letter of credit or other security provided by the CUSTOMER. LES shall have the right to adjust the total payment required by the CUSTOMER, as previously described, at its sole discretion.
5. EDR is not available to a new CUSTOMER which results from a change in ownership of an existing establishment without qualifying new load. However, if a change in ownership occurs after the CUSTOMER enters into an EDR Service Agreement for service under this EDR, the successor CUSTOMER shall be allowed to fulfill the balance of the EDR Service Agreement under this EDR. EDR is also not available for renewal of service following interruptions such as equipment failure, temporary plant shutdown, strike, or economic conditions. EDR is not available for load shifted from one CUSTOMER to another within LES' service area.
6. In the event of suspension of the EDR, existing EDR customers will continue to receive credits with continued adherence to the Terms and Conditions and the EDR Service Agreement.
7. All EDR loads must be separately metered. For existing customers, this may require a submeter.
8. For LES economic development information, or questions about the administration of the EDR, please contact the Vice President, Customer Services at 402-475-4211.

## Schedule INT – INTERRUPTIBLE SERVICE RIDER

**AVAILABLE:** Within Lincoln, Nebraska, and the LES Service Area.

**APPLICABLE:** To any CUSTOMER not on the Curtailment Rider taking service under the following LES rate schedules:

Schedule LLP – Large Light & Power 15 (Secondary), 16 (Primary), & 39 (35 kV)

Schedule LPC – Large Power Customer 44 (Secondary), 45 (Primary), & 46 (35 kV)

Supplemental Firm Power Contracts

**CHARACTER OF SERVICE:** As identified under the applicable rate schedule.

**DEMAND:** The integrated kilowatt load during any 30-minute period.

**FIRM LOAD:** The portion of DEMAND a CUSTOMER defines as uninterruptible.

**INTERRUPTIBLE LOAD:** The portion of a CUSTOMER's load which is in excess of its FIRM LOAD and can be reduced upon notice by LES.

**INTERRUPTIBLE CREDIT:** The credit, in dollars, provided to a CUSTOMER in exchange for being able to interrupt a portion of their load.

**INTERRUPTION PERIOD:** The time, when called on by LES, the CUSTOMER will be required to reduce their load to not exceed their FIRM LOAD.

**FAILURE TO INTERRUPT PENALTY:** This penalty shall be the peak INTERRUPTIBLE LOAD, during an event in which the CUSTOMER does not reduce their DEMAND below their FIRM LOAD, multiplied by the FAILURE TO INTERRUPT PENALTY rate.

*FAILURE TO INTERRUPT PENALTY*

$$= (\text{INTERRUPTIBLE LOAD during INTERRUPTION PERIOD} - \text{FIRM LOAD}) \\ * \text{FAILURE TO INTERRUPT PENALTY Rate}$$

**BILL:** All charges applicable under the metered rate schedule plus the INTERRUPTIBLE CREDIT or FAILURE TO INTERRUPT PENALTY.

**BILLING PERIOD:** BILLS are rendered on a calendar-month basis or a date agreeable with LES for final readings.

**RATE:** At the end of the BILLING PERIOD LES will apply an INTERRUPTIBLE CREDIT to the CUSTOMER's BILL for all DEMAND in excess of the CUSTOMER's FIRM LOAD.

**Schedule INT – INTERRUPTIBLE SERVICE RIDER**

- Prior to the beginning of each calendar year, LES and the CUSTOMER will review the CUSTOMER’s load profile. During this time the CUSTOMER will notify LES what portion of their DEMAND will be FIRM LOAD for the next year.
- After the beginning of the year, when called upon, the CUSTOMER must reduce their DEMAND to at or below, their FIRM LOAD.
- If a CUSTOMER fails to reduce their DEMAND to at or below their FIRM LOAD, a FAILURE TO INTERRUPT PENALTY shall be applied to the bill for each event (there could be more than one event in a BILLING PERIOD), and no INTERRUPTIBLE CREDIT will be applied for that BILLING PERIOD.
- To accommodate unforeseen changes, a CUSTOMER may contact LES to adjust their FIRM LOAD designation one time during a calendar year.

<b>INTERRUPTIBLE RIDER</b>	<b>Rate</b>
Interruptible Credit \$/kW of INTERRUPTIBLE LOAD	(\$5.14)
Failure to Interrupt Penalty \$/kW of INTERRUPTIBLE LOAD during INTERRUPTION PERIOD	\$51.40

**TERMS AND CONDITIONS:**

1. Service will be furnished subject to LES' policies and Service Regulations.
2. TERMS OF PAYMENT - BILLS on active accounts are due in full 23 days after rendered. BILLS on final accounts are due upon receipt or the date of the most recently issued BILL, whichever is later. Any past due amounts are subject to LES policies regarding termination of electric service and applicable Service Fees. Charges are subject to all applicable State and Local sales tax.
3. All applicable Terms and Conditions from the CUSTOMER’s applicable rate schedule apply.
4. LES will notify CUSTOMERS at least 30 minutes, and when possible, up to 24 hours, prior to an INTERRUPTION PERIOD.
5. INTERRUPTION PERIODS can take place at any time and can last for up to 4 hours.
6. There will be no more than 20 INTERRUPTION PERIODS in a calendar year.
7. If during a calendar year, a CUSTOMER opts to no longer participate in the Interruptible Service Rider, INTERRUPTIBLE CREDITS received by the CUSTOMER for that calendar year must be paid back to LES. In addition, the CUSTOMER will not be eligible for the Interruptible Service Rider for a period of one year from the date of going off the Interruptible Service Rider. In addition, FAILURE TO INTERRUPT PENALTY amounts will not be charged to the CUSTOMER.
8. The CUSTOMER will furnish, install and maintain all equipment necessary to measure and provide interruption capability. The CUSTOMER is responsible for all CUSTOMER equipment operation and maintenance. LES assumes no liability for the operation and maintenance of the CUSTOMER's equipment or for protection of any property or person associated with the CUSTOMER's business operation, and the CUSTOMER agrees to indemnify and hold LES harmless from any claim or liability resulting from the interruptible service to be provided pursuant to this Interruptible Service Rider or from any load interruption request.

**Schedule PA – POLE ATTACHMENT – 50**

**AVAILABLE:** Within Lincoln, Nebraska, and the LES Service Area.

**APPLICABLE:** To other utilities and certain entities which may occupy public right-of-way and who attach communication cables and other communication appliances on LES poles where such attachments are made in accordance with National Electrical Safety Code (NESC) and local laws; and are in compliance with the provisions of an applicable Pole Attachment Contract, if any.

**CHARACTER OF SERVICE:** Generally attachments are made on poles at heights stipulated by the National Electrical Safety Code (<http://standards.ieee.org/about/nesc/>).

**ANNUAL ATTACHMENT RATE:**

<b>POLE ATTACHMENT</b>	<b>Rate</b>
Pole Attachment (\$/Year)	\$17.00

**TERMS AND CONDITIONS:**

1. LES approval is required before attachments are made to poles.
2. TERMS OF PAYMENT - BILLS on active accounts are due in full 23 days after rendered. BILLS on final accounts are due upon receipt or the date of the most recently issued BILL, whichever is later. Any past due amounts are subject to LES policies regarding termination of electric service and applicable Service Fees. Charges are subject to all applicable State and Local sales tax.
3. The attaching entity shall pay the non-betterment cost for any LES work required to accommodate the pole attachment.
4. The annual attachment bill shall be based on the number of attachments to LES poles as of November 30. No prorating is allowed.
5. The attaching entity shall, at its own expense, install, maintain, transfer and relocate attachments in accordance with LES requirements and standards of the National Electrical Safety Code.
6. The attaching entity shall indemnify, protect and save harmless LES and its officers, agents and employees, from and against any and all claims, demands, suits, judgments, liabilities, loss, damages, which may arise out of or be caused by the erection, maintenance, presence, use or removal of their equipment.
7. The attaching entity shall notify LES of all pole attachment removals.

**Schedule PA – POLE ATTACHMENT – 50**

8. LES may require removal of pole attachments if any of the following occur:
  - a. The attaching entity fails to pay attachment fees or other charges when due.
  - b. The attaching entity uses its equipment in such a manner as to adversely affect LES' equipment, LES' service to others, or creates a hazard.
  - c. The attaching entity fails to comply with any of the other terms and conditions of this rate, LES' Service Regulations, or the provisions of an applicable contract.
  - d. LES removes the pole(s).
9. Other provisions for attachments will be provided for as necessary and regulated under a required Pole Attachment Contract between the utility or entity and LES, or as provided in the rules and procedures established by LES.

## **TAX CLAUSE**

**AVAILABLE:** Within Lincoln, Nebraska, and the LES Service Area.

**APPLICABLE:** To any CUSTOMER taking service from LES, unless proper tax exemption certificate is presented.

In the event of the imposition of any new or increased tax or any payment in lieu thereof, in excess of that provided for under Article VIII, Section 12 of the Charter of the City of Lincoln, the rate provided herein may be increased to reflect the amount of such tax or in lieu of tax increase.

# NON-RETAIL PRICING

### Schedule VNM – VIRTUAL NET METERING RIDER

**AVAILABLE:** To CUSTOMERS billed on the Residential, General Service or Heating Service rate schedule.

**APPLICABLE:** The charges and credits (payments) of this rider will apply to CUSTOMERS who enroll in the LES virtual net metering program (“VNM Program”). Only a CUSTOMER with an acceptable payment history, as determined by LES, will qualify for this rider.

**CHARACTER OF SERVICE:** The VNM Program is a way for customers to virtually serve part of their energy consumption with solar power from the LES Community Solar Project located at 7501 W Holdrege St. This VNM Program replicates net metering benefits without an actual customer-owned installation. All energy provided to the CUSTOMER in excess of the virtual net metering generation will continue to be provided and billed under the appropriate rate schedule. The character of the electric service received is identified under the applicable rate schedule.

**PURCHASE OF OUTPUT FROM VIRTUAL NET METERING CUSTOMERS:** A CUSTOMER in the VNM Program will be allowed to use the electrical output of the virtual generation to supply all or a portion of their own load and deliver the surplus to LES.

**RATE:** At the end of the BILLING PERIOD, LES will net the metered energy which was supplied by LES, the Renewable Net Meter energy delivered to LES by the CUSTOMER, and the virtual solar energy delivered to LES by the CUSTOMER.

- Energy supplied by LES to the CUSTOMER in a BILLING PERIOD will be billed at the applicable retail rate.
- The net amount of energy supplied to the CUSTOMER is calculated in this specific order: the energy supplied by LES, less any renewable net meter energy delivered to LES, less the virtual solar energy delivered to LES.
- Any virtual solar energy in excess of the net amount of energy provided to the CUSTOMER in a BILLING PERIOD will be purchased by LES at LES’ avoided cost.
- Other applicable fees and charges, including the Customer Charge and the Facilities Charge, will be billed to the CUSTOMER at the applicable retail rate.
- Sales tax will be applied to the net amount of energy provided to the CUSTOMER.

Virtual solar energy delivered to LES by a CUSTOMER will be based on the following:

Number of virtual panels subscribed by the CUSTOMER *multiplied by* (Total kWh produced by the LES Community Solar Project in the previous calendar month *divided by* 15,333 total panels in the LES Community Solar Project).

Virtual solar energy delivered to LES will appear as credits on the BILL. Credits which exceed charges for a BILLING PERIOD will roll-over to the following BILLING PERIOD. At the end of each calendar year, any credits remaining will be paid by check from LES in the final BILLING PERIOD of the year.

### Schedule VNM – VIRTUAL NET METERING RIDER

**ENROLLMENT:** The enrollment fee will be based on the number of virtual panels subscribed by the CUSTOMER and the Program Rate that is in effect on the date of enrollment (see table below). A CUSTOMER will have the option to pay the Program Rate in either (a) one lump sum at the time of enrollment or (b) on a monthly basis over a 36-month period. Monthly payments will be fixed at the Program Rate in effect on the date of enrollment for the entire 36-month term.

Enrollment will be limited to increments of half panels. Sales tax will be assessed at the time of the enrollment. The sales tax rate will be determined by the address of the CUSTOMER.

A CUSTOMER'S enrollment level will be limited to the lesser of the following:

- (a) Whole number of virtual panels with Projected Annual Production (see table below) equivalent to no more than 80% of the CUSTOMER'S net energy consumption in the previous twelve-month period of December 1 through November 30, or as determined by LES.
- (b) 100 virtual panels, which is approximately commensurate to the 25 kW<sub>AC</sub> production capacity limit under Schedule RNM, Renewable Net Metering Rider.

**CANCELLATION:** LES will provide compensation, including the sales tax on the refund amount, to a CUSTOMER upon cancellation. The compensation will be based on the number of virtual panels being cancelled by the CUSTOMER and the Refund Rate that is in effect on the date of cancellation (see table below).

For any virtual panel that is still under an active 36-month payment period, the portion of the virtual panel being cancelled will be prorated according to the Equivalent Virtual Panel Subscribed, calculated per the following:

$$\text{Equivalent Virtual Panel Subscribed} = \frac{\text{Total payments to date } (\$)}{36 \text{ Month Program Rate} * 36}$$

**RESTRICTIONS:** During the final five calendar years of the program (2032 – 2036), no new enrollments or increases in existing enrollment will be allowed. Full or partial cancellation will be allowed at any time.

**RENEWABLE ENERGY CERTIFICATES:** All renewable energy certificates related to virtual solar energy production will be retired by LES on behalf of the CUSTOMER.

#### TERMS AND CONDITIONS:

1. This is an incentive program that is subject to review and revision. LES will resolve discrepancies or other issues regarding interpretation or implementation of the VNM Program.
2. The VNM Program will terminate on July 1, 2036. Enrollment of all participating CUSTOMERS will be canceled and all related energy purchases by LES will cease.
3. Projected Annual Production is an estimate based on the expected LES Community Solar Project output. While not expected, there could be periods where there is no output. LES makes no guarantee of actual output levels.

**Schedule VNM – VIRTUAL NET METERING RIDER**

4. VNM Program enrollment is specific to the CUSTOMER and non-transferrable.
5. It is LES' understanding that VNM Program enrollment does not entitle the CUSTOMER to federal tax credits related to the LES Community Solar Project or the energy produced.

<b>Year</b>	<b>One-Time Program Rate (\$/virtual panel)</b>	<b>36-Month Program Rate (\$/virtual panel/month)</b>	<b>Refund Rate (\$/virtual panel)</b>	<b>Projected Annual Production (kWh<sub>AC</sub>/virtual panel)</b>
2017	\$685.00	N/A	\$515.00	515
2018	\$665.00	N/A	\$500.00	513
2019	\$640.00	\$18.30	\$480.00	510
2020	\$620.00	\$17.80	\$465.00	508
2021	\$595.00	\$17.00	\$445.00	505
2022	\$570.00	\$15.90	\$430.00	502
2023	\$540.00	\$15.50	\$405.00	500
2024	\$510.00	\$14.60	\$385.00	497
2025	\$480.00	\$13.80	\$360.00	495
2026	\$450.00	\$12.90	\$340.00	493
2027	\$420.00	\$12.00	\$315.00	490
2028	\$385.00	\$11.00	\$290.00	488
2029	\$350.00	\$10.00	\$265.00	485
2030	\$310.00	\$8.90	\$235.00	483
2031	\$270.00	\$7.70	\$205.00	480
2032	N/A	N/A	\$100.00	478
2033	N/A	N/A	\$75.00	476
2034	N/A	N/A	\$50.00	473
2035	N/A	N/A	\$25.00	471
2036	N/A	N/A	\$0.00	468

**Schedule RNM – 25 kW<sub>AC</sub>  
RENEWABLE NET METERING RIDER**

**AVAILABLE:** To renewable generation with production capacity of 25 kW<sub>AC</sub> or less, in conjunction with a retail load. No single METER may exceed 25 kW<sub>AC</sub>. Renewable generation includes electric generators powered by methane, wind, solar, biomass, hydro or waste technologies. New renewable generation will be placed on this rider until the total generating capacity of all renewable generation using net metering is equal to or exceeds one percent (1.0%) of the capacity necessary to meet LES' average aggregate CUSTOMER monthly peak demand forecast for that calendar year. At that point, this rider will no longer be offered to CUSTOMERS.

**APPLICABLE:** The credits (payments) of this rider will apply to CUSTOMERS with renewable generation who purchase energy from LES under an appropriate retail rate and who may supply energy to LES.

**CHARACTER OF SERVICE:** Unless otherwise provided by contract, the character of purchased power will be single- or three-phase alternating electric current at 60 hertz. Voltage shall be determined by the voltage of LES' distribution system in the vicinity unless otherwise agreed. Facilities on this service will be metered with an LES supplied bi-directional meter.

**PURCHASE OF OUTPUT FROM RENEWABLE GENERATOR CUSTOMERS:** Owners of renewable generation will be allowed to parallel these facilities with LES and use the electrical output of their renewable generation to supply all or a portion of their own load and deliver the surplus to LES.

**RATE:** At the end of the BILLING PERIOD, LES will net the metered energy which was delivered to LES and the metered energy which was supplied by LES.

- Net energy supplied by LES to the CUSTOMER in a BILLING PERIOD will be billed at the applicable retail rate.
- Net energy delivered to LES in a BILLING PERIOD will be purchased by LES at the applicable Renewable Net Metering Rider Energy Payment rate.
- Other applicable fees and charges, including the Customer Charge, the Facilities Charge and the Demand Charge (if any), will be billed to the CUSTOMER at the applicable retail rate.

Purchases by LES will appear as credits on the BILL. Credits which exceed charges for a BILLING PERIOD will roll-over to the following BILLING PERIOD. At the end of each calendar year, any credits remaining will be paid by check from LES in the final BILLING PERIOD of the year.

**Schedule RNM – 25 kW<sub>AC</sub>  
 RENEWABLE NET METERING RIDER**

**Renewable Net Metering Rider Energy Payment rate:** The Energy Payment rate will be the Energy Charge based on the Tier (see table below) that is in effect on the date of the interconnection with LES (bi-directional meter set) and the Energy Payment rate will remain at this Tier for 10 years (regardless of any changes in the underlying Tier) from the month of the interconnection or the year 2014, whichever comes later.

The Customer Charge and the Facilities Charge will be equal to the Customer Charge and the Facilities Charge for the applicable retail customer class as determined and periodically adjusted by LES.

Subsequent to the first ten years of a CUSTOMER’S initial LES-approved installation, the Energy Payment rate will transition to the Tier that is currently in effect and will continue to transition to each subsequent Tier as of the effective date for each Tier as determined by LES.

If a CUSTOMER increases the renewable generation production capacity at the same CUSTOMER location for which the CUSTOMER has an existing Renewable Net Metering Agreement with LES, the Energy Payment rate of the expanded facility will coincide with the timing and provisions of the Tier for the existing facility; except that the total renewable generation production capacity may not exceed 25 kW<sub>AC</sub> for a single METER.

<b>RENEWABLE NET METERING RIDER</b>	<b>Summer</b>	<b>Winter</b>
Tier 1 Energy Payment rate for energy delivered to the SYSTEM, \$/kWh	100% of the current Residential Energy Charge	
Tier 2 Energy Payment rate for energy delivered to the SYSTEM, \$/kWh	50% of the current Residential Energy Charge	
Tier 3 Energy Payment rate for energy delivered to the SYSTEM, \$/kWh	To Be Determined	

In no case will the Energy Payment rate be less than [LES’ Avoided Cost](#) of electricity.

**TIER DEFINITIONS:**

- **Tier 1:** Tier 1 will be defined as the period up to the point where there is total CUSTOMER renewable energy generation of one (1) megawatt<sub>AC</sub> as determined by LES, or May 31, 2024, whichever is earlier. Tier 1 closed on December 31, 2017.
- **Tier 2:** Tier 2 will be defined as the period when Tier 1 ends (December 31, 2017) and up to the point where there is total CUSTOMER renewable energy generation of ten (10) megawatts<sub>AC</sub> as determined by LES, or 15 years after the Tier 2 commencement date, whichever is earlier.
- **Tier 3:** Tier 3 will be defined as the period when Tier 2 ends.

**Schedule RNM – 25 kW<sub>AC</sub>  
RENEWABLE NET METERING RIDER**

**CAPACITY PAYMENT:** LES will make a one-time Capacity Payment to the owner of the renewable generation based on the contribution of peak reduction by the renewable resource, valued at a traditional resource cost of \$1,000 per kW<sub>AC</sub>. Capacity increases or additions in future years will be eligible for the Capacity Payment based on the then current Capacity Payment. The Capacity Payment will be paid on the following basis:

- Predominantly southern facing fixed solar: \$375.00 per kW<sub>DC</sub> of nameplate capacity.
- Predominantly western facing fixed solar: \$475.00 per kW<sub>DC</sub> of nameplate capacity.
- Single or dual-axis tracking solar: \$475.00 per kW<sub>DC</sub> of nameplate capacity.
- Other solar installations: No Capacity Payment.
- Wind: No Capacity Payment.
- Other technologies besides solar and wind: \$1,000.00 per average kW<sub>AC</sub> net demand output of the generation at 5:00 pm during the months of July and August (as determined by LES).

Capacity Payments may be adjusted based on the value to LES and Capacity Payments will terminate effective with the commencement of Tier 3.

**TERMS AND CONDITIONS:**

1. This is an incentive rate rider that is subject to review and revision as new technologies and economic factors change. LES will resolve discrepancies or other issues regarding interpretation or implementation of this rate rider.
2. A signed written agreement between the renewable generator CUSTOMER and LES will be required. [View the Net Metering 25 kW<sub>AC</sub> or less Agreement for Interconnection of Customer-Owned Generation.](#)
3. The renewable generation's connection to LES' distribution system must pass an inspection by LES for safety and power quality.
4. The renewable generator CUSTOMER must supply a meter socket and a disconnect switch between the renewable generation/inverter and LES' service drop.
5. The renewable generator CUSTOMER must comply with all applicable city, county, and state sales tax, laws and regulations.
6. Service will be furnished subject to LES' policies and Service Regulations, and the [Net Metering 25 kW<sub>AC</sub> or less Agreement for Interconnection of Customer-Owned Generation.](#)

### Schedule REC - Renewable Energy Certificate Rider

**AVAILABLE:** Within Lincoln, Nebraska, and the LES Service Area.

**APPLICABLE:** The charges of this rider will apply to CUSTOMERS who enroll in the LES renewable energy certificate rider (“REC Rider”). Only a CUSTOMER with an acceptable payment history, as determined by LES, will qualify for this rider.

**CHARACTER OF SERVICE:** The character of the electric service received is as identified under the applicable rate schedule. The REC represents the renewable aspect of the energy produced at LES resources. Purchasing a REC certifies that the renewable energy is being generated on behalf of the customer.

**BILL:** CUSTOMER Bill under applicable rate schedule + REC Charge

**RATE:**

<b>RENEWABLE ENERGY CERTIFICATE RIDER</b>	<b>Rate</b>
Enrollment Fee (One time at enrollment) \$/account	\$10.00
REC Charge \$/kWh	\$0.00206

**TERMS AND CONDITIONS:**

1. Service will be furnished subject to LES' Policies and Service Regulations.
2. TERMS OF PAYMENT - BILLS on active accounts are due in full 23 days after rendered. BILLS on final accounts are due upon receipt or the date of the most recently issued BILL, whichever is later. Any past due amounts are subject to the LES Policy – Termination of Electric Service and applicable Service Fees. Charges are subject to all applicable State and Local sales tax.
3. All applicable Terms and Conditions from the CUSTOMER's applicable rate schedule apply.
4. Enrollment of 100% of a CUSTOMERS energy consumption is required.
5. This program is 100 percent voluntary.
6. LES will establish the REC Charge once per year, based on market conditions.

### **Schedule REC - Renewable Energy Certificate Rider**

7. At the end of each year, all RECs sold under this rider will be retired by LES on behalf of the CUSTOMER.
8. Participation in the REC Rider will continue each month until LES is notified to discontinue participation by the CUSTOMER.
9. LES has a limited number of RECs. LES does not guarantee that RECs will be available to all customers. LES reserves the right to suspend the REC Rider at any time.
10. If a CUSTOMER moves within the LES service territory, the REC Rider will be automatically applied to the new location unless LES is notified otherwise.
11. While supplies last, LES will match each REC purchased by a CUSTOMER with a free REC from LES' federal hydropower allocation. LES' hydropower RECs cannot be resold but may be retired on behalf of an LES CUSTOMER.

**Schedule RG – RENEWABLE GENERATION**  
**(Intended for Generation Without Load, 26 kW<sub>AC</sub>-100 kW<sub>AC</sub>)**

**AVAILABLE:** To renewable generation with production capacity of greater than 25 kW<sub>AC</sub> and less than, or equal to, 100 kW<sub>AC</sub>. No single CUSTOMER or project location may exceed 100 kW<sub>AC</sub>. Renewable generation includes electric generators powered by methane, wind, solar, biomass, hydro or waste technologies. New renewable generation will be placed on the Renewable Generation Rate until the total generating capacity of all renewable generation on the Renewable Generation Rate (not including Renewable Net Metering projects) is equal to or exceeds one percent (1.0%) of the capacity necessary to meet LES' average aggregate CUSTOMER monthly peak demand forecast for that calendar year. At that point, this schedule will no longer be offered to CUSTOMERS.

**APPLICABLE:** The charges and credits (payments) of this rate will apply to CUSTOMERS with renewable generation who supply energy to LES. This rate is intended to limit renewable generation to projects of greater than 25 kW<sub>AC</sub> and less than, or equal to, 100 kW<sub>AC</sub> per CUSTOMER or location to allow for diversity in CUSTOMER participation in this incentive rate. LES will make the final determination as to whether a proposed renewable generation project qualifies for the Renewable Generation Rate.

**CHARACTER OF SERVICE:** Unless otherwise provided by contract, the character of purchased power will be single- or three-phase alternating electric current at 60 hertz. Voltage shall be determined by the voltage of LES' distribution system in the vicinity unless otherwise agreed. Facilities on this service will be metered with an LES supplied bi-directional meter. The Renewable Generation Rate is intended for generation without load (other than generation auxiliaries and related systems). Any netting of energy is expected to be minimal.

**PURCHASE OF OUTPUT FROM RENEWABLE GENERATOR CUSTOMERS:** Owners of renewable generation will be allowed to parallel these facilities with LES and sell energy to LES. Energy generated cannot be used to offset a CUSTOMER'S load. Positive net energy delivered to the CUSTOMER in more than two BILLING PERIODS in a 12 month period will immediately disqualify this service from continuing to receive this Renewable Generation Rate for a period of one year from the date of disqualification. Such disqualification will cause this service to be billed at the applicable retail energy rate and energy delivered to LES will be credited at the Small Power Production rate.

**RATE:** At the end of the BILLING PERIOD, LES will net the metered energy which was delivered to LES and any incidental metered energy which was supplied by LES.

- Net energy delivered to LES in a BILLING PERIOD will be purchased by LES at the CUSTOMER'S appropriate Renewable Generation Rate Energy Payment rate.
- Net energy supplied by LES to the CUSTOMER in a BILLING PERIOD will be billed at the General Service retail energy rate. Any netting of energy is expected to be minimal.
- Other applicable fees and charges, including the Customer Charge, the Facilities Charge, the Distribution Facilities Charge, the City Dividend for Utility Ownership and Sales Tax (if applicable) will be billed to the CUSTOMER.

Purchases by LES will appear as credits on the BILL. Credits which exceed charges for a BILLING PERIOD will be paid by check from LES. Owners of renewable generation will be allowed to allocate credits to designated participant properties or as applied to individual tenant accounts as part of the Multi-tenant Shared Solar Rate.

**Schedule RG – RENEWABLE GENERATION  
 (Intended for Generation Without Load, 26 kW<sub>AC</sub>-100 kW<sub>AC</sub>)**

**Renewable Generation Rate Energy Payment rate:** The Energy Payment rate will be the Energy Charge based on the Tier (see table below) that is in effect on the date the Renewable Generation up to 100 kW<sub>AC</sub> Application for Review of Interconnection and Parallel Operation of Customer-Owned Generation (Application for Review) is approved by LES. This Energy Payment rate will remain fixed at this level for 10 years (regardless of any changes in the underlying Tier or Energy Charge) from the month of the date of the interconnection with LES (bi-directional meter set) as long as the Parallel Operations, Power Sales and Interconnection Agreement is approved and site inspection is conducted within one year of submitting the Application for Review.

The Customer Charge and the Facilities Charge will be equal to the General Service Customer Charge and Facilities Charge as determined and periodically adjusted by LES. The Distribution Facilities Charge will be as identified on this rate schedule and as determined and periodically adjusted by LES.

Subsequent to the first ten years of a CUSTOMER’S initial LES-approved installation, the Energy Payment rate will transition to the Tier that is currently in effect and will continue to transition to each subsequent Tier as of the effective date for each Tier as determined by LES.

If a CUSTOMER increases the renewable generation production capacity at the same CUSTOMER location for which the CUSTOMER has an existing Renewable Generation Rate Agreement with LES, the Energy Payment rate of the expanded facility will coincide with the timing and provisions of the Tier for the existing facility; except that the total renewable generation production capacity may not exceed 100 kW<sub>AC</sub> for a CUSTOMER or single location.

<b>RENEWABLE GENERATION RATE</b>	<b>Summer</b>	<b>Winter</b>
Tier 1 Energy Payment rate for energy delivered to the SYSTEM, \$/kWh	100% of the Residential Energy Charge in effect at the time Application for Review is approved	
Tier 2 Energy Payment rate for energy delivered to the SYSTEM, \$/kWh	50% of the Residential Energy Charge in effect at the time Application for Review is approved	
Tier 3 Energy Payment rate for energy delivered to the SYSTEM, \$/kWh	To Be Determined	
Distribution Facilities Charge \$/BILL	\$27.00	
Customer Charge \$/BILL	\$6.50	
Facilities Charge Single Phase \$/BILL	\$31.00	
Facilities Charge Three Phase \$/BILL	\$95.50	
Facilities Charge Primary \$/BILL	\$50.00	

In no case will the Energy Payment rate be less than the [LES Avoided Cost](#).

**Schedule RG – RENEWABLE GENERATION  
(Intended for Generation Without Load, 26 kW<sub>AC</sub>-100 kW<sub>AC</sub>)**

**TIER DEFINITIONS:**

- **Tier 1:** Tier 1 will be defined as the period up to the point where there is total CUSTOMER renewable energy generation of one (1) megawatt<sub>AC</sub> as determined by LES, or May 31, 2024, whichever is earlier. Tier 1 closed on December 31, 2017.
- **Tier 2:** Tier 2 will be defined as the period when Tier 1 ends (December 31, 2017) and up to the point where there is total CUSTOMER renewable energy generation of ten (10) megawatts<sub>AC</sub> as determined by LES, or 15 years after the Tier 2 commencement date, whichever is earlier.
- **Tier 3:** Tier 3 will be defined as the period when Tier 2 ends.

**CAPACITY PAYMENT:** LES will make a one-time Capacity Payment to the owner of the renewable generation based on the contribution of peak reduction by the renewable resource, valued at a traditional resource cost of \$1,000.00 per kW<sub>AC</sub>. Capacity increases or additions in future years will be eligible for the Capacity Payment based on the then current Capacity Payment. The Capacity Payment will be paid on the following basis:

- Predominantly southern facing fixed solar: \$375.00 per kW<sub>DC</sub> of nameplate capacity.
- Predominantly western facing fixed solar: \$475.00 per kW<sub>DC</sub> of nameplate capacity.
- Single or dual-axis tracking solar: \$475.00 per kW<sub>DC</sub> of nameplate capacity.
- Other solar installations: No Capacity Payment.
- Wind: No Capacity Payment
- Other technologies besides solar and wind: \$1,000.00 per average kW<sub>AC</sub> net demand output of the generation at 5:00 p.m, during the months of July and August (as determined by LES).

Capacity Payments may be adjusted based on the value to LES and Capacity Payments will terminate effective with the commencement of Tier 3.

**TERMS AND CONDITIONS:**

1. This is an incentive rate that is subject to review and revision as new technologies and economic factors change. LES will resolve discrepancies or other issues regarding interpretation or implementation of this rate.
2. A signed written agreement between the renewable generator CUSTOMER and LES will be required. [View the Renewable Generation up to 100 kW<sub>AC</sub> Agreement for Interconnection of Customer-Owned Generation.](#)
3. The renewable generation's connection to LES' distribution system must pass an inspection by LES for safety, power quality and verification that no loads are drawing power from LES.

**Schedule RG – RENEWABLE GENERATION**  
**(Intended for Generation Without Load, 26 kW<sub>AC</sub>-100 kW<sub>AC</sub>)**

4. The renewable generator CUSTOMER must supply a meter socket and a disconnect switch between the renewable generation/inverter and LES' service drop.
5. The renewable generator CUSTOMER must comply with all applicable city, county, and state sales tax, laws and regulations.
6. Service will be furnished subject to LES' policies and Service Regulations, Lincoln Building & Safety codes and the [Renewable Generation up to 100 kW<sub>AC</sub> Agreement for Interconnection](#).
7. Any proposed generation installation of 25 kW<sub>AC</sub> or greater requires approval by the Nebraska Power Review Board and a review by LES for system adequacy. Proof of approval by the Nebraska Power Review Board must be provided to LES prior to interconnection to LES.
8. For renewable generation installations above 100 kW<sub>AC</sub>, contact LES for the appropriate rates and interconnection requirements.

### Schedule SS - SUNSHARES RIDER

**AVAILABLE:** Within Lincoln, Nebraska, and the LES Service Area.

**APPLICABLE:** To any CUSTOMER.

**CHARACTER OF SERVICE:** SunShares is a way to support operation of a utility scale photovoltaic array. No energy will be supplied to CUSTOMERS under this rider. All energy provided to CUSTOMERS will continue to be provided and billed under appropriate rate schedules. The character of the electric service received is as identified under the applicable rate schedule.

**BILL:** SunShares Contribution plus all charges applicable under the metered rate schedule.

**BILLING PERIOD:** BILLING PERIODS are based on a monthly schedule set in the applicable rate schedule.

**RATE:**

SunShares Contribution: \$1.00 per SunShare per BILLING PERIOD  
Minimum contribution is three (3) SunShares per BILLING PERIOD. Other monthly contributions in even dollar amounts and one-time contributions are available.

**TERMS AND CONDITIONS:**

1. Service will be furnished subject to LES' policies and Service Regulations.
2. TERMS OF PAYMENT - BILLS on active accounts are due in full 23 days after rendered. BILLS on final accounts are due upon receipt or the date of the most recently issued BILL, whichever is later.
3. This program is 100% voluntary.
4. Participation in SunShares will continue each month until LES is notified in writing.
5. SunShares Contributions are not subject to sales tax

**Schedule C&SPP-100 kW<sub>AC</sub>**  
**COGENERATION AND SMALL POWER PRODUCTION**

**AVAILABLE:** To cogeneration and small power production facilities with production capacity of 100 kW<sub>AC</sub> and less that qualify under the guidelines for implementing Public Utility Regulatory Policies Act (PURPA) Sections 201 and 210 as adopted by the LES Administrative Board.

**CHARACTER OF SERVICE:** Unless otherwise provided by contract, the character of purchased power will be single or three phase alternating electric current at 60 hertz. Voltage shall be determined by the voltage of LES' distribution system in the vicinity unless otherwise agreed.

**PURCHASE OF OUTPUT FROM QUALIFYING FACILITIES:** Owners of Qualifying Facilities will be allowed the option to either (1) sell the entire electrical output of their Qualifying Facilities to LES, or (2) use the electrical output of their Qualifying Facilities to instantaneously supply all or a portion of their own load and sell the instantaneous surplus to LES.

**PURCHASE PRICE** Energy will be purchased from the CUSTOMER at the [LES Avoided Cost](#) for that Period.

<b>COGENERATION &amp; SMALL POWER PRODUCTION PURCHASE</b>	<b>Summer</b>	<b>Winter</b>
Energy Price \$/kWh for all power and/or energy delivered to the Lincoln Electric System	LES Avoided Cost for the Period	LES Avoided Cost for the Period

**SEASONAL PROVISION:** Summer and winter periods are defined as:

Summer – The four-month period from June 1 through September 30

Winter – The eight-month period from October 1 through May 31

Energy Charge on the BILL will be prorated between seasons in transitional months (i.e., June and October) according to the number of days corresponding to each season covered by the BILL.

**Schedule C&SPP-100 kW<sub>AC</sub>**  
**COGENERATION AND SMALL POWER PRODUCTION**

**TERMS AND CONDITIONS:**

1. A signed written agreement between the Qualifying Facility and LES will be required.
2. Unless modified by contract, LES' policies and Service Regulations shall apply to this schedule.
3. For facilities with more than 100 kW<sub>AC</sub> of capacity, the purchase rate and other terms and conditions will be determined on a case-by-case basis.
4. Application and interconnectivity must be compliant with the Policy and Guidelines for Customer-Owned Generation.
5. TERMS OF PAYMENT - BILLS on active accounts are due in full 23 days after rendered. BILLS on final accounts are due upon receipt or the date of the most recently issued BILL, whichever is later. Any past due amounts are subject to LES policies regarding termination of electric service and applicable Service Fees. Charges are subject to all applicable State and Local sales tax.
6. FLUCTUATING LOADS AND HARMONICS – CUSTOMERS operating equipment causing harmonic currents and/or highly fluctuating or large instantaneous demands, including, but not limited to, variable speed drives, motor starting, welders and X-ray machines, shall be required to pay all nonbetterment costs of corrective action required to maintain acceptable service quality to the CUSTOMER and not interfere with service on LES' lines or to other CUSTOMERS. See System Disturbances and Service Disruptions, and Disconnection of Electric Service in the Service Regulation.

## **SCHEDULE RGS – RENEWABLE GENERATION STANDBY CAPACITY RIDER**

**AVAILABLE:** Within Lincoln, Nebraska, and the LES Service Area.

**APPLICABLE:** A CUSTOMER under contract will receive service on this schedule as part of a contract for electric service if the following conditions are met:

- a) The CUSTOMER takes service under one of the following LES rate schedules:
  - Schedule LLP – Large Light & Power 15 (Secondary), 16 (Primary), & 39 (35 kV)
  - Schedule LPC – Large Power Customer 44 (Secondary), 45 (Primary), & 46 (35 kV)
  - Schedule GSD – General Service Demand 11 (Secondary), & 12 (Primary)
- b) The CUSTOMER has renewable generation facilities of at least 100 kW<sub>AC</sub> consisting of qualifying generation facilities status pursuant to Public Utility Regulatory Policies Act of 1978 (PURPA) and Federal Energy Regulatory Commission (FERC) regulations with or without battery storage.
- c) The CUSTOMER'S generation facilities operate in parallel to LES' generation facilities.
- d) The CUSTOMER and LES have entered into an interconnection agreement covering the CUSTOMER's generating facilities for which supplemental and backup power is being requested.

For new CUSTOMER accounts added to LES, usage and demand projections will be prepared by LES' Energy Delivery Division prior to being placed on the rider.

**CHARACTER OF SERVICE:** As identified under the applicable rate schedule.

**BILLING PERIOD:** BILLS are rendered on a calendar-Month basis or a date agreeable with LES for final readings.

## SCHEDULE RGS – RENEWABLE GENERATION STANDBY CAPACITY RIDER

**DEFINITIONS:** The following definitions are applicable to this schedule, and some refer to the metering diagram below.

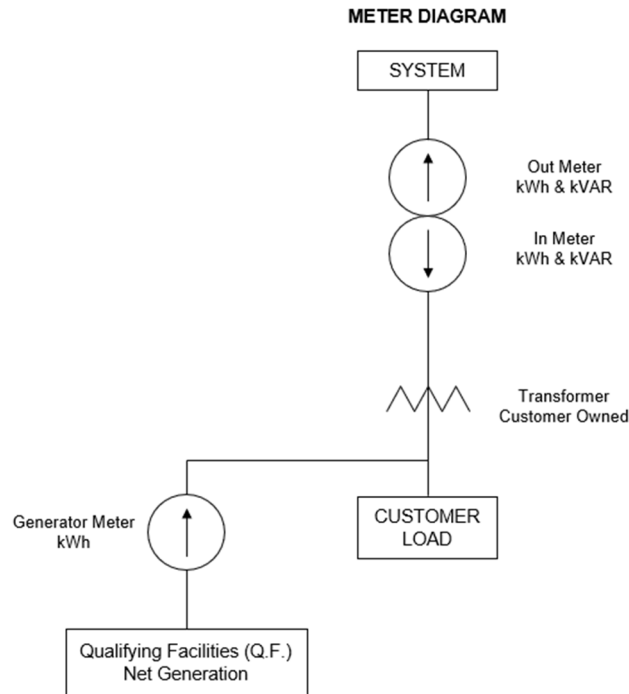

All meters are detented so only power flowing in the indicated direction is measured. Generator Meter readings are multiplied by 1.003 to bring them to the same voltage as the In Meter.

- **Qualifying Facility-Demand:** The integrated kilowatt output of the CUSTOMER's generator during 30-minute periods as measured by the Generator Meter minus the Out Meter. If there is no Out Meter, the Out Meter reading will be zero. Depending on how the CUSTOMER's generation support equipment is connected, the Qualifying Facility-Demand may be either gross or net generator output.
- **Qualifying Facility-Energy:** The sum of the 30-minute Qualifying Facility-Demand over the total BILLING PERIOD in kilowatt-hours as measured by the Generator Meter, all divided by two.
- **Delivered Power-Demand:** The integrated kilowatt load during 30-minute periods as measured by the In Meter.
- **Delivered Power-Energy:** The sum of the 30-minute Delivered Power-Demand over the total BILLING PERIOD in kilowatt-hours as measured by the In Meter, all divided by two.

**SCHEDULE RGS – RENEWABLE GENERATION STANDBY CAPACITY RIDER**

- **Total Customer Demand:** The integrated kilowatt load during 30-minute periods as measured by the In Meter plus the Generator Meter minus the Out Meter. If there is no Out Meter, the Out Meter reading will be zero.
- **Total Customer Energy:** The sum of the 30-minute Total Customer Demand over the total BILLING PERIOD in kilowatt-hours as measured by the In Meter plus Generator Meter, all divided by two.
- **Excess Energy:** Energy supplied to the system that is measured by the difference between the Total Customer Energy and Qualifying Facility-Energy over the total BILLING PERIOD. If the value is greater than zero Excess energy reading will be zero. If value is less than zero, the absolute value of the difference will be used.

**SEASONAL PROVISION:** Summer and winter periods are defined as:

Summer – The four-month period from June 1 through September 30

Winter – The eight-month period from October 1 through May 31

**PURCHASE OF OUTPUT FROM RENEWABLE GENERATOR CUSTOMERS:** Owners of renewable generation will be allowed to parallel these facilities with LES and use the electrical output of their renewable generation to supply all or a portion of their own load and deliver the surplus to LES.

**BILLING DEMAND:**

- **BILLED DELIVERED DEMAND:** Is either (a) or (b), whichever is higher, if the CUSTOMER receives service at the LLP rates. If service is received at GSD rates it is either (a), (b), or (c), whichever is higher, and if at LPC rates it is either (a), (b), or (d), whichever is higher:
  - a) The max Delivered Power-Demand during the Billing Period
  - b) 65 percent of the highest established BILLED DELIVERED DEMAND for the bills rendered for June, July, August or September of the preceding 11 months.
  - c) 25 kW
  - d) 4,000 kW
- **BILLED TOTAL CUSTOMER DEMAND:** Is either (a) or (b), whichever is higher, if the CUSTOMER receives service at the LLP rates. If service is received at GSD rates it is either (a), (b), or (c), whichever is higher, and if at LPC rates it is either (a), (b), or (d), whichever is higher:
  - a) The max Total Customer Demand during the Billing Period
  - b) 65 percent of the highest BILLED TOTAL CUSTOMER DEMAND established for the bills rendered for June, July, August or September of the preceding 11 months.
  - c) 25 kW
  - d) 4,000 kW

**SCHEDULE RGS – RENEWABLE GENERATION STANDBY CAPACITY RIDER**

**RATE:**

**Demand and Standby Charge:** Under this rider the CUSTOMER will no longer be billed their regular Demand Charge as written in their applicable rate schedule. Instead, they will pay a new Demand Charge and a Standby Charge. The Demand Charge will be billed at the CUSTOMER’S BILLED DELIVERED DEMAND and the Standby Charge will be billed at the CUSTOMER’S BILLED TOTAL CUSTOMER DEMAND.

**Energy Payment:** The Energy Payment rate will be set at the customer’s applicable rate’s Energy Charge for Summer and Winter.

<b>RENEWABLE GENERATION STANDBY CAPACITY RIDER</b>	<b>Summer</b>	<b>Winter</b>
15 LLP Demand Charge, \$/kW of BILLED DELIVERED DEMAND		\$12.00
15 LLP Standby Charge, \$/kW of BILLED TOTAL CUSTOMER DEMAND		\$5.75
16 LLP Demand Charge, \$/kW of BILLED DELIVERED DEMAND		\$11.50
16 LLP Standby Charge, \$/kW of BILLED TOTAL CUSTOMER DEMAND		\$5.75
39 LLP Demand Charge, \$/kW of BILLED DELIVERED DEMAND		\$11.50
39 LLP Standby Charge, \$/kW of BILLED TOTAL CUSTOMER DEMAND		\$5.75
44 LPC Demand Charge, \$/kW of BILLED DELIVERED DEMAND		\$12.50
44 LPC Standby Charge, \$/kW of BILLED TOTAL CUSTOMER DEMAND		\$5.50
45 LPC Demand Charge, \$/kW of BILLED DELIVERED DEMAND		\$12.00
45 LPC Standby Charge, \$/kW of BILLED TOTAL CUSTOMER DEMAND		\$5.30
46 LPC Demand Charge, \$/kW of BILLED DELIVERED DEMAND		\$12.00
46 LPC Standby Charge, \$/kW of BILLED TOTAL CUSTOMER DEMAND		\$5.30
11 GSD Demand Charge, \$/kW of BILLED DELIVERED DEMAND		\$10.15
11 GSD Standby Charge, \$/kW of BILLED TOTAL CUSTOMER DEMAND		\$4.35
12 GSD Demand Charge, \$/kW of BILLED DELIVERED DEMAND		\$10.00
12 GSD Standby Charge, \$/kW of BILLED TOTAL CUSTOMER DEMAND		\$4.25
Energy Payment for Excess Energy, \$/kWh	Applicable Rate Energy Charge	

**Facilities Charge:** The CUSTOMER will face the same Facilities Charge as written in their applicable rate schedule. The CUSTOMER’S BILLED DEMAND for the charge will change to be the CUSTOMER’S BILLED TOTAL CUSTOMER DEMAND

The CUSTOMER’S remaining charges will be billed as described in their applicable rate schedule for any service LES provides.

## **SCHEDULE RGS – RENEWABLE GENERATION STANDBY CAPACITY RIDER**

### **TERMS AND CONDITIONS:**

1. A signed written agreement between the renewable generator CUSTOMER and LES will be required.
2. The renewable generation's connection to LES' distribution system must pass an inspection by LES for safety, power quality and verification that no loads are drawing power from LES.
3. The renewable generator CUSTOMER must supply a meter socket and a disconnect switch between the renewable generation/inverter and LES' service drop.
4. The renewable generator CUSTOMER must comply with all applicable city, county, and state sales tax, laws and regulations.
5. Service will be furnished subject to LES' policies and Service Regulations, Lincoln Building & Safety codes and written agreement with LES.

**Schedule MTSS – MULTI-TENANT SHARED SOLAR**

**AVAILABLE:** To Multi-tenant Property Owners (defined as owners of dwellings accommodating and occupied by more than two families, excluding townhomes) of residential properties, with renewable generation greater than 100 kW<sub>AC</sub> but no greater than 120% of estimated annual multi-tenant facility load as approved by LES. Renewable generation includes electric generators powered by methane, wind, solar, biomass, hydro or waste technologies.

**APPLICABLE:** The charges and credits (payments) of this rate will apply to CUSTOMERS with renewable generation who supply energy to LES. The CUSTOMER will be charged and credited under this rate type of service and level of renewable generation. LES will make the final determination as to whether a proposed renewable generation project qualifies for the Multi-tenant Shared Solar rate.

**CHARACTER OF SERVICE:** Unless otherwise provided by contract, the character of purchased power will be single- or three-phase alternating electric current at 60 hertz. Voltage shall be determined by the voltage of LES' distribution system in the vicinity unless otherwise agreed. Facilities on this service will be metered with an LES supplied bi-directional meter. The Renewable Generation Rate is intended for generation without load (other than generation auxiliaries and related systems). Any netting of energy is expected to be minimal.

**PURCHASE OF OUTPUT FROM RENEWABLE GENERATOR CUSTOMERS:** Owners of renewable generation will be allowed to parallel these facilities with LES and sell energy to LES. Energy purchases by LES are limited to a maximum of 120% of the estimated annual load of all properties included in the Shared Renewable Bill Credit Allocation Program. Energy generated cannot be used to offset a CUSTOMER'S load. Positive net energy delivered to the CUSTOMER in more than two BILLING PERIODS in a 12-month period will immediately disqualify this service from continuing to receive this Multi-Tenant Shared Solar Rate for a period of one year from the date of disqualification. Such disqualification will cause this service to be billed at the applicable retail energy rate and energy delivered to LES will be credited at the Small Power Production rate.

**Shared Renewable Bill Credit Allocation Program (also see Schedule SRCA):** To designate allocation of credits, Multi-tenant Property Owners must submit a Shared Renewable Bill Credit Allocation Form providing the building address for each renewable generator and the addresses and unit numbers which should receive bill credits. Renewable generators are not required to be collocated on the property receiving the energy credits nor will there be a limit to the number of units that can receive monthly energy credits. A one-time setup fee of \$10 per unit will be assessed to the CUSTOMER (the Multi-tenant Property Owner) for enrollment in the program.

**Schedule MTSS – MULTI-TENANT SHARED SOLAR**

**RATE:** At the end of the BILLING PERIOD, LES will net the metered energy which was delivered to LES and any incidental metered energy which was supplied by LES. LES will allocate net energy and associated credits generated to each of the multi-tenant CUSTOMERS, equally or as designated by the Multi-tenant Property Owner in their Shared Renewable Bill Credit Allocation Form.

- Net energy delivered to LES in a BILLING PERIOD will be purchased by LES at the CUSTOMER’S appropriate Renewable Generation Rate Energy Payment rate.
- Net energy supplied by LES to the renewable system in a BILLING PERIOD will be billed at the General Service retail energy rate and be paid by the CUSTOMER (Multi-tenant Property Owner).
- Other applicable fees and charges, including the Customer Charge, the Facilities Charge, the Distribution Facilities Charge, the City Dividend for Utility Ownership and Sales Tax (if applicable) will be netted from the credited energy. The remaining credit will be distributed to multi-tenant CUSTOMERS as outlined in the Shared Renewable Bill Credit Allocation Form.

Purchases by LES will appear as credits on the BILL. Credits which exceed charges for a BILLING PERIOD will be paid by check from LES.

**Renewable Generation Rate Energy Payment rate:** The Energy Payment rate will be the set at LES daytime avoided cost.

The Customer Charge and the Facilities Charge will be equal to the General Service Customer Charge and Facilities Charge as determined and periodically adjusted by LES. The Distribution Facilities Charge will be as identified on this rate schedule and as determined and periodically adjusted by LES.

<b>MULTI-TENANT SHARED SOLAR RATE</b>	<b>Summer</b>	<b>Winter</b>
Energy Payment rate for energy delivered to the SYSTEM, \$/kWh	LES Seasonal Daytime Avoided Cost	
Distribution Facilities Charge \$/BILL	\$27.00	
Customer Charge \$/BILL	\$6.50	
Facilities Charge Single Phase \$/BILL	\$31.00	
Facilities Charge Three Phase \$/BILL	\$95.50	
Facilities Charge Primary \$/BILL	\$50.00	
Enrollment Fee for Shared Renewable Credit Allocation Program \$/unit	\$10.00	

### **Schedule MTSS – MULTI-TENANT SHARED SOLAR**

#### **TERMS AND CONDITIONS:**

1. This is an incentive rate that is subject to review and revision as new technologies and economic factors change. LES will resolve discrepancies or other issues regarding interpretation or implementation of this rate.
2. A signed written agreement between the renewable generator CUSTOMER and LES will be required.
3. The renewable generator must be interconnected to LES' distribution system and pass an inspection by LES for safety, power quality and verification that no loads are drawing power from LES.
4. The renewable generator CUSTOMER must supply a meter socket and a disconnect switch between the renewable generation/inverter and LES' service drop.
5. The renewable generator CUSTOMER must comply with all applicable city, county, and state sales tax, laws and regulations.
6. Service will be furnished subject to LES' policies and Service Regulations, Lincoln Building & Safety codes and the written agreement with LES.
7. Any proposed generation installation of 25 kW<sub>AC</sub> or greater requires approval by the Nebraska Power Review Board and a review by LES for system adequacy. Proof of approval by the Nebraska Power Review Board must be provided to LES prior to interconnection to LES.

### Schedule SRCA – Shared Renewable Credit Allocation

**AVAILABLE:** Within Lincoln, Nebraska, and LES Service Area.

**APPLICABLE:** To any CUSTOMER that is placed under the Shared Renewable Bill Credit Allocation Program by their property owner.

**CHARACTER OF SERVICE:** As identified under the applicable rate schedule.

**RATE:** CUSTOMER will receive a credit on their bill for their allocated share of the property owner's renewable generation.

RENEWABLE GENERATION RATE	Summer	Winter
Shared Renewable Credit	Share of Renewable Credit as allocated by the property owner.	

#### TERMS AND CONDITIONS:

1. Service will be furnished subject to LES' policies and Service Regulations.
2. TERMS OF PAYMENT - BILLS on active accounts are due in full 23 days after rendered. BILLS on final accounts are due upon receipt or the date of the most recently issued BILL, whichever is later. Any past due amounts are subject to LES policies regarding termination of electric service and applicable Service Fees. Charges are subject to all applicable State and Local sales tax.
3. FLUCTUATING LOADS AND HARMONICS – CUSTOMERS operating equipment causing harmonic currents and/or highly fluctuating or large instantaneous demands, including, but not limited to, variable speed drives, motor starting, welders and X-ray machines, shall be required to pay all nonbetterment costs of corrective action required to maintain acceptable service quality to the CUSTOMER and not interfere with service on LES' lines or to other CUSTOMERS. See System Disturbances and Service Disruptions, and Disconnection of Electric Service in the Service Regulations.
4. COGENERATION OR SMALL POWER PRODUCTION - Refer to Customer-Owned Generation in the Service Regulations.

### Schedule NORRIS PUBLIC POWER DISTRICT

**AVAILABLE:** Within LES and Norris Joint Use Area.

**APPLICABLE:** This schedule is applicable to Norris Public Power District for their Wholesale power needs in the LES and Norris Joint Use Area.

**CHARACTER OF SERVICE:** To be determined by engineering staff at the points of integration of the LES and Norris systems.

**BILL:** Customer Charge + Demand Charge + Facilities Charge + Energy Charge; based on the RATE in effect and LES' Service Regulations.

**BILLING PERIOD:** BILLS are rendered on a calendar-month basis or a date agreeable with LES for final readings.

**SEASONAL PROVISION:** Summer and winter periods are defined as:

Summer – The four-month period from June 1 through September 30

Winter – The eight-month period from October 1 through May 31

**RATE:**

Norris Joint Use Area	Summer	Winter
Customer Charge \$/BILL	\$500.00	
Demand Charge Secondary \$/kW of BILLING DEMAND	\$17.25	
Facilities Charge Secondary \$/kW of BILLING DEMAND	\$2.70	
Energy Charge \$/kWh	\$0.0230	\$0.0215

**MAXIMUM DEMAND:** The highest integrated kilowatt load during any 60-minute period occurring in the BILLING PERIOD for which the determination is made.

**BILLING DEMAND:** Either (a) or (b), whichever is higher:

(a) The MAXIMUM DEMAND occurring during the BILLING PERIOD.

(b) 65 percent of the highest MAXIMUM DEMAND established for the BILLS rendered for June, July, August or September of the preceding 11 months.

**TERMS AND CONDITIONS:**

1. Service will be furnished subject to LES' policies and Service Regulations.
2. Norris will provide LES interval data from the applicable customers in order to determine billing and cost of service.
3. TERMS OF PAYMENT - BILLS on active accounts are due in full 23 days after rendered. BILLS on final accounts are due upon receipt or the date of the most recently issued BILL, whichever is later. Any past due amounts are subject to LES policies regarding termination of electric service and applicable Service Fees. Charges are subject to all applicable State and Local sales tax.

**Schedule Norris**

4. FLUCTUATING LOADS AND HARMONICS – CUSTOMERs operating equipment causing harmonic currents and/or highly fluctuating or large instantaneous demands, including, but not limited to, variable speed drives, motor starting, welders and X-ray machines, shall be required to pay all nonbetterment costs of corrective action required to maintain acceptable service quality to the CUSTOMER and not interfere with service on LES' lines or to other CUSTOMERS. See System Disturbances and Service Disruptions, and Disconnection of Electric Service in the Service Regulations.

### Schedule SF – SERVICE FEES

**AVAILABLE:** Within Lincoln, Nebraska, and the LES Service Area.

**APPLICABLE:** To any CUSTOMER taking service from LES.

#### CUSTOMER SERVICE FEES:

##### New Service Fee

Applicable to every new account, move, transfer, etc., upon the request for service initiation. (Excluding accounts with a current Landlord Options form on file.) \$10

##### Late Payment Fee

Applicable to all accounts for amounts not paid by the due date on or after the first business day past the due date. 3.0 Percent of Past Due Amount

##### Disconnection Charge for Nonpayment

Applicable when credit representative visits premises for disconnection due to delinquency but does not disconnect service.

Disconnection Reminder Charge. \$10

Applicable to delinquent accounts.

Basic disconnection. \$65

Meter technician disconnection. \$115

Line crew disconnection. \$200

##### After-Hours Reconnection Charge

Applicable when line crew reconnects service outside of normal weekday business hours on an account that was disconnected due to delinquency. \$100

##### Returned Payment Fee

Applicable to accounts when a CUSTOMER'S payment is returned to LES from a financial institution. \$15

##### Inaccessible Meter Fee

Applicable when an attempt by LES to read, service or access a METER is unsuccessful. \$75

##### Mislabeled Meter Sockets or Cross Wiring Fee

Applicable when LES is required to correct property-owner's mislabeled meters or cross-wired services. \$80 / hour / employee

##### Temporary Service Fee

Applicable when a temporary service and meter are required. \$200

##### Meter Tampering Fee

Applicable each time LES discovers a tampered, bypassed, or otherwise misused METER. \$315

**Schedule SF – SERVICE FEES**

Residential Line Extension Fee:

A fee charged for a portion of the construction cost.

Underground Extension (Subdivision):	\$472 for lots with rear lot lines 100 ft. in width or less OR \$4.72 per rear lot foot for lots with rear lot line greater than 100 ft. in width, not to exceed \$944 per lot
Underground Primary Extension (Single Acreage-Non Subdivisions):	\$944 minimum
Underground Extension (Mobile Home Parks):	\$175 per lot

CUSTOMER Requested Outage:

A fee charged for switching functions to de-energize and re-energize LES facilities.

Customer requested switching rate for overnight hours (10:00 PM – 8:00 AM):	\$500
Customer requested switching rate for Sundays and Holidays:	\$700

# **CITY DIVIDEND FOR UTILITY OWNERSHIP**

**Schedule CD – CITY DIVIDEND FOR UTILITY OWNERSHIP**

**AVAILABLE:** Within Lincoln, Nebraska, and the LES Service Area.

**APPLICABLE:** To any CUSTOMER taking any service listed below.

**CITY DIVIDEND FOR UTILITY OWNERSHIP:** The City Dividend for Utility Ownership is added to the following rate schedules. The City Dividend is charged sales tax. Charges will be pro-rated on the CUSTOMER’S first and final BILLS according to the number of days covered by the BILL. The City Dividend shall be adjusted on September 1 each year.

Residential (Rate Codes 01, 03)	\$ 3.83 per BILL
General Service (Rate Codes 10, 13, RG)	Single-phase: \$ 5.37 per BILL Three-phase: \$ 16.74 per BILL
Heating Service (Rate Codes 21, 23)	Single-phase: \$ 13.28 per BILL Three-phase: \$ 39.31 per BILL Large & Primary: \$ 145.08 per BILL
General Service-Demand (Rate Codes 11, 12)	\$ 0.00439 per kWh
Large Light & Power and Supplemental Firm Power (Rate Codes 15, 16, 27, 28, 29, 31, 32, 39, 42, 61, 62)	\$ 0.00426 per kWh
Large Power Customer (Rate Codes 44, 45, 46, 47, 48, 49, 53)	\$ 0.00333 per kWh
Large Power with Market Energy (Rate Code 55)	\$ 3.33 per MWh
Traffic Lighting (Rate Code 24)	\$ 0.74 per BILL
Street Lighting (Rate Code 26)	\$ 2.99 per BILL